

Air and Vacuum Sewer Valves



SA SERIES

Air and Vacuum Sewer Valves

Valve Function

- Exhausts air as a pipeline fills, and allows air in as pipeline drains

Features Include

- Standard and short body series available
- Available in sizes 2" thru 10"

Stainless Steel Trim Standard

Air and Vacuum Sewer Valves permit a large volume of air to be released from a pipeline when it is filling. It also allows air into a system when draining.

CRISPIN Air and Vacuum Sewer Valves feature a rigid stainless steel valve plug to seal off the outlet orifice. As a result, damage to the seating surface is much less likely to occur in surge conditions.

A drawing of a typical Sewer Air and Vacuum Valve seating area is shown below. The valve plug is protected from a rush of air by a stainless steel baffle. The baffle provides a rigid support for the float guide bushing while allowing the float rod enough clearance for self seating operation.

The CRISPIN Air and Vacuum Sewer Valve, like the light body Pressure Sewer Valve, is designed for a maximum cold water working pressure of 300 PSIG.

Any combination of the Sewer Air and Vacuum Valve and Sewer Pressure Air Release Valve can be made with the appropriate piping arrangements to accommodate a specific application.

All CRISPIN Air and Vacuum Valves have standard Buna-N seating material with a Shore durometer of 70-80. This standard seat allows drip tight closure beyond 4-5 PSIG. Occasionally, a gravity system operates at pressures less than 10 PSIG. These applications require a soft seating material which will prevent leakage down to 2 PSIG. This soft seating material should not be applied to systems with operating pressures greater than 50 PSIG, or high pressure leaks may occur around the seat.

Short Air & Vacuum Sewer Series

MODEL	INLET	OUTLET	HEIGHT
S10AS	2" screwed	1" screwed	12 1/2"
S10ASB	2" screwed	1" screwed	16 3/4"
S20AS	2" screwed	2" screwed	12 1/2"
S20ASB	2" screwed	2" screwed	16 3/4"

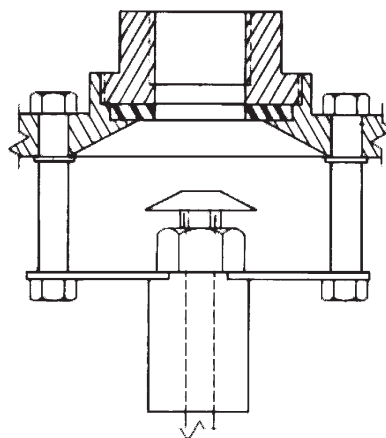

Where height restrictions do not permit the use of the standard height valve, a short body Sewer Air and Vacuum or Pressure Air Release Valve can be supplied. Their function is identical to the standard Sewer Valves except that they operate in a shorter body.



SA SERIES

Air and Vacuum Sewer Valves

Air and Vacuum Sewer Valves

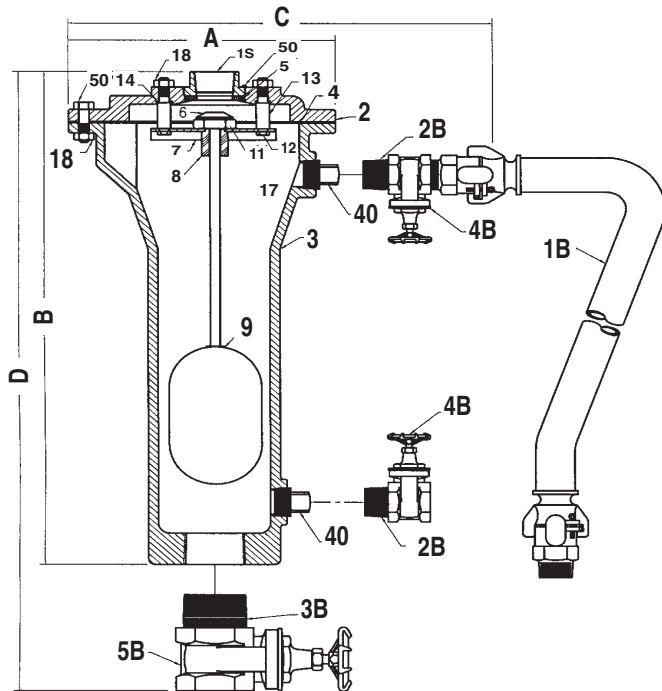

Backflush Optional

Parts List

PART NO.	ITEM	MATERIAL
1	TOP	Cast Iron
2	FLANGE	Cast Iron
3	BODY, SCREW	Cast Iron
3F	BODY, FLANGE	Cast Iron
4	FLANGE GASKET	Armstrong
5	SEAT	Buna-N Rubber
6	VALVE & FLOAT ROD	Stainless Steel
7	ROD GUIDE STAND	Stainless Steel
8	FLOAT ROD GUIDE	Nylatron
9	FLOAT	Stainless Steel
11	ROD GUIDE NUT	Stainless Steel
12	STAND ROD SCREW	Stainless Steel
13	STAND ROD SCREW	Stainless Steel
14	STAND ROD GASKET	Fibre
15	STAND ROD NUT	Steel
17	FLANGE BOLT	Steel
18	FLANGE NUT	Steel
33	FLUSH PLUG	Steel

Standard Capacity/Light Body Series

Model	Inlet NPT	Outlet NPT	Width	Width w/Back Flush	Height	Height w/Back Flush	Wt.	Wt. w/Back Flush
SL20A	2"	1"	9-11/16"	1-3/4"	21-1/2"	25-1/4"	49	60

Note: Operating pressures below 20 PSIG require soft seating material.

Dimensions and Weights

Model	Inlet	Outlet NPT	Height	Width	Height w/Back Flush	Width w/Back Flush	Wt.	Wt. w/Back Flush
S20A	2" NPT	2"	25 1/2"	10 1/16"	29 1/4"	13-1/2"	93	105
S21A	2" 125# Flg.	2"	29"	10 1/16"	36 1/4"	13-1/2"	95	136
S30A	3" NPT	3"	21 3/4"	10"	27 1/4"	13-1/2"	100	117
S31A	3" 125# Flg.	3"	21 3/4"	10"	29 7/16"	13-1/2"	110	163
S40A	4" NPT	4"	23 1/4"	11 1/2"	29"	16"	120	149
S41A	4" 125# Flg.	4"	23 1/4"	11 1/2"	32 1/4"	16"	135	193
S61A	6" 125# Flg.	6"	26 3/8"	14 1/2"	37"	16-1/4"	210	350
S81A	8" 125# Flg.	8"	25 5/16"	17 3/4"	37"	22-1/4"	335	550
S101A	10" 125# Flg.	10"	36 1/4"	21 1/4"	39-1/2"	24"	500	780

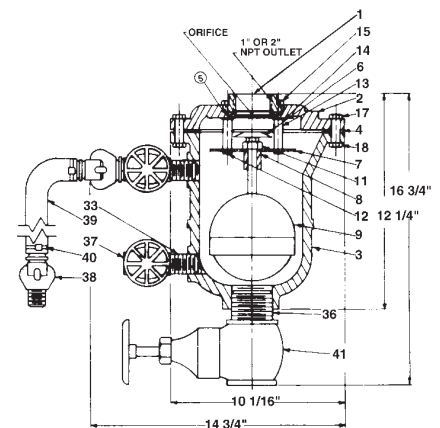

*All Crispin valves are hydrostatically tested at 150% of their maximum working pressure.

Back flushing attachments are available with any sewer valve arrangement and include: isolation gate valve, 2 - 1" flushing valves and 5' of 1" hose with quick disconnect attachments.

Submittal Sheet for Crispin SA Series

2" Air/Vacuum Sewer Valve (standard)

Manufactured in compliance with ANSI/AWWA C512

Date: October, 2001



SUBMITTAL SHEET FOR SA SERIES

Specifications

Air and Vacuum Release Valve(s) shall be installed at high points in the main line, or as directed by the engineer. This will permit the release of air as the main is filling, or relieve the vacuum as the main is draining or is under negative pressure.

The valve(s) shall be of the long body design, and shall operate by sealing the Buna-N Rubber seat with a stainless steel valve disc as the float rises when water enters the valve body. The valve(s) shall automatically open when the system drains, or is under negative pressure, so that air may enter the line.

Valve construction shall be _____ " NPT screwed or ANSI Class (125, 250) flanged inlet connection, and shall be cast iron body, top and inlet flange (where required), stainless steel trim and float. The outlet connection shall be cast iron body, top and inlet float (where required), stainless steel trim and float. The outlet shall be _____ " NPT screwed.

The valve(s) shall be Crispin Model _____ Air and Vacuum Sewer Valves, as manufactured by Crispin-Multiplex Manufacturing Co., Berwick, PA.

Option: The valve(s) shall be supplied with back flushing attachments so that the interior body can be flushed periodically for proper operation.

Option: A protectop shall be supplied to prevent debris from entering the outlet of the valve.

Option: Where pressures are greater than 300 PSIG, the valve(s) shall be ANSI Class _____ flanged inlet connection, and shall have a (steel, stainless steel, or ductile iron) body, top and inlet flange.

Standard operating pressure for Crispin Air Valves is 20 to 150 PSIG. Please check one of the following if your operating needs differ:
 _____ 2 to 40 PSIG _____ 151 to 300 PSIG

* Parts are interchangeable and optional at customer's request.

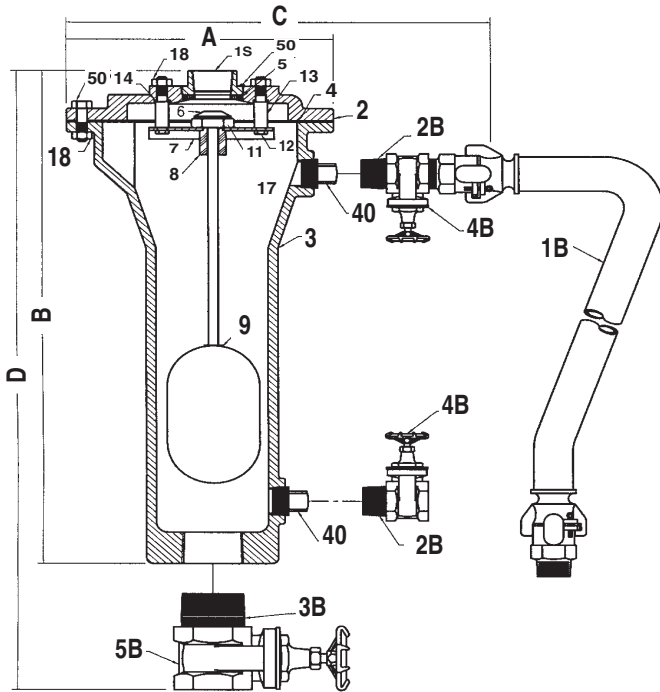

Parts List

ITEM	DESCRIPTION	MATERIAL	ASTM
1S	TOP	CAST IRON	A126 CL.B
2	FLANGE	CAST IRON	A126 CL.B
3	BODY	CAST IRON	A126 CL.B
4	FLANGE GASKET	ARMSTRONG N-8092	N/A
5	SEAT	BUNA-N RUBBER	D2000
6	VALVE & FLOAT ROD	STAINLESS STEEL	A582
7	ROD GUIDE STAND	STAINLESS STEEL	A240
8	FLOAT ROD GUIDE	NYLATRON	D5989
9	FLOAT	STAINLESS STEEL	A240
11	ROD GUIDE NUT	STAINLESS STEEL	A194
12	STAND ROD SCREW	STAINLESS STEEL	A193
13	STAND ROD	STAINLESS STEEL	A582
14	STAND ROD GASKET	FIBER	D710
17	BOLT	STEEL	A307
18	NUT	STEEL	A563
*40	DRAIN PLUG	CAST IRON	A126 CL.B
50	INTERFERENCE PIN	STAINLESS STEEL	A582

OPTIONAL BACK FLUSH COMPONENTS

*1B	HOSE ASSEMBLY	CAD.PLT STEEL&RUBBER	N/A
*2B	NIPPLE	STEEL	A53
*3B	NIPPLE	STEEL	A53
*4B	GATE VALVE	BRASS	N/A
*5B	GATE VALVE	BRASS	N/A

Size Specifications

MODEL	INLET SIZE	OUTLET SIZE	A	B	C	D	WHT.
SL20A	2" NPT	1" NPT	9.75	21.50			49
SL20AB	2" NPT	1" NPT			11.75	25.75	60



Submittal Sheet for Crispin SA Series

2"–4" Air/Vacuum Sewer Valve (high)

Manufactured in compliance with ANSI/AWWA C512

Date: October, 2001

Specifications

Air & Vacuum Sewer Valve(s) shall be installed at high points in the main line, or as directed by the engineer. This will permit the release of air as the main is filling, or relieve the vacuum as the main is draining or under negative pressure.

Valve construction shall be _____" NPT screwed or ANSI Class (125, 250) flanged inlet connection, and shall be cast iron body, top and inlet flange (where required), stainless steel trim and float. The outlet connection shall be cast iron body, top and inlet float (where required), stainless steel trim and float. The outlet shall be _____" NPT screwed.

The valve(s) shall be Crispin Model _____ Air and Vacuum Sewer Valves, as manufactured by Crispin-Multiplex Manufacturing Co., Berwick, PA.

Option: The valve(s) shall be supplied with back flushing attachments so that the interior body can be flushed periodically for proper operation.

Option: A protectop shall be supplied to prevent debris from entering the outlet of the valve.

Option: Where pressures are greater than 300 PSIG, the valve(s) shall be ANSI Class _____ flanged inlet connection, and shall have a (steel, stainless steel, or ductile iron) body, top and inlet flange.

Standard operating pressure for Crispin Air Valves is 20 to 150 PSIG. Please check one of the following if your operating needs differ:

____ 2 to 40 PSIG ____ 151 to 300 PSIG

Size Specifications

MODEL	INLET SIZE	OUTLET SIZE	A	B	C	D	WT.
S20A	2" NPT	2" NPT	10.25	25.50			90
**S21A	2" 125# FLG	2" NPT	10.25	29.00			96
S20AB	2" NPT	2" NPT			13.50	29.25	102
**S21AB	2" 125# FLG	2" NPT			13.50	36.25	127
S30A	3" NPT	3" NPT	10.00	21.75			100
S31A	3" 125# FLG	3" NPT	10.00	21.75			110
S30AB	3" NPT	3" NPT			13.50	27.25	115
S31AB	3" 125# FLG	3" NPT			13.50	29.75	160
S40A	4" NPT	4" NPT	11.50	23.25			120
S41B	4" 125# FLG	4" NPT	11.50	23.25			135
S40AB	4" NPT	4" NPT			16.00	29.00	149
S41AB	4" 125# FLG	4" NPT			16.00	32.25	215

* Parts are interchangeable and optional at customer's request.

**Includes ANSI CL.125 companion FLG and nipple

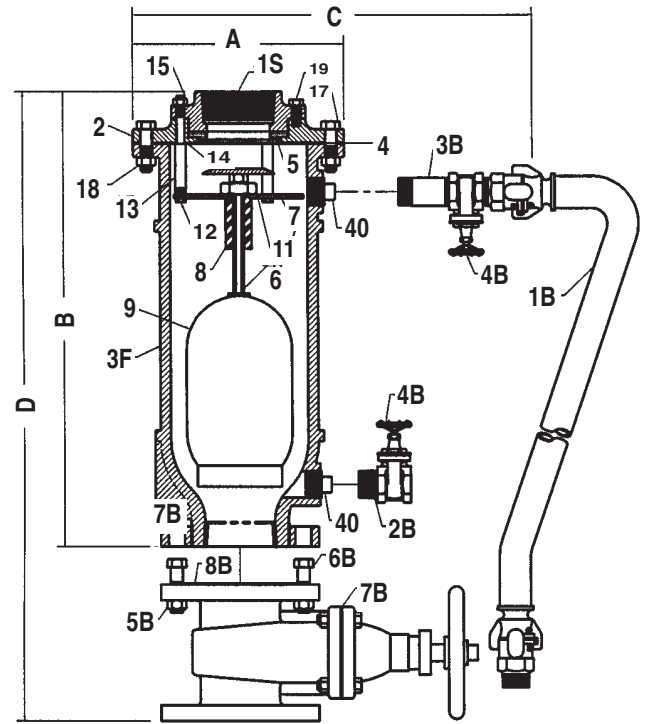

Parts List

ITEM	DESCRIPTION	MATERIAL	ASTM
1S	TOP	CAST IRON	A126 CL.B
2	FLANGE	CAST IRON	A126 CL.B
3	BODY	CAST IRON	A126 CL.B
4	FLANGE GASKET	ARMSTRONG N-8092	N/A
5	SEAT	BUNA-N RUBBER	D2000
6	VALVE & FLOAT ROD	STAINLESS STEEL	A276/A312
7	ROD GUIDE STAND	STAINLESS STEEL	A240
8	FLOAT ROD GUIDE	NYLATRON	N/A
9	FLOAT	STAINLESS STEEL	A240
11	ROD GUIDE NUT	STAINLESS STEEL	A194
12	STAND ROD SCREW	STAINLESS STEEL	A193
13	STAND ROD	STAINLESS STEEL	A312
14	STAND ROD GASKET	FIBER	D710
15	STAND ROD NUT	STEEL	A563
17	FLANGE BOLT	STEEL	A307
18	FLANGE NUT	STEEL	A563
19	BOLT	STEEL	A307
*40	PLUG	CAST IRON	A126 CL.B

OPTIONAL BACK FLUSH COMPONENTS

*1B	HOSE ASSEMBLY	CAD.PLT STEEL & RUBBER	N/A
*2B	1" X CL. NIPPLE	STEEL	A312
*3B	1" X 3" NIPPLE	STEEL	A312
*4B	1" GATE VALVE	BRASS	N/A
*5B	NUT	STEEL	A563
*6B	BOLT	STEEL	A307
*7B	3" GATE VALVE	CAST IRON	N/A
*8B	GASKET	ARMSTRONG N-8092	N/A

SUBMITTAL SHEET FOR SA SERIES

Submittal Sheet for Crispin SA Series

6"-10" Air/Vacuum Sewer Valve (high)

Manufactured in compliance with ANSI/AWWA C512

Date: October, 2001



SUBMITTAL SHEET FOR SA SERIES

Specifications

Air and Vacuum Sewer Valve(s) shall be installed at high points in the main line, or as directed by the engineer. This will permit the release of air as the main is filling, or relieve the vacuum as the main is draining or is under negative pressure.

Valve construction shall be _____" NPT screwed or ANSi Class (125, 250) flanged inlet connection, and shall be cast iron body, top and inlet flange (where required), stainless steel trim and float. The outlet connection shall be cast iron body, top and inlet float (where required), stainless steel trim and float. The outlet shall be _____" NPT screwed.

The valve(s) shall be Crispin Model _____ Air and Vacuum Sewer Valves, as manufactured by Multiplex Manufacturing Co., Berwick, PA.

Option: The valve(s) shall be supplied with back flushing attachments so that the interior body can be flushed periodically for proper operation.

Option: A protectop shall be supplied to prevent debris from entering the outlet of the valve.

Option: Where pressures are greater than 300 PSIG, the valve(s) shall be ANSi Class _____ flanged inlet connection, and shall have a (steel, stainless steel, or ductile iron) body, top and inlet flange.

Standard operating pressure for Crispin Air Valves is 20 to 150 PSIG. Please check one of the following if your operating needs differ:

____ 2 to 40 PSIG ____ 151 to 300 PSIG

* Parts are interchangeable and optional at customer's request.

Size Specifications

MODEL	INLET SIZE	OUTLET SIZE	A	B	C	D	WT.
S61A	6" 125# FLG	6" NPT	14.50	26.50			210
S61AB	6" 125# FLG	6" NPT			16.25	37.00	358
S81A	8" 125# FLG	8" NPT	17.75	25.50			335
S81AB	8" 125# FLG	8" NPT			22.25	37.00	550
S101A	10" 125# FLG	10" NPT	21.25	36.25			500
S101AB	10" 125# FLG	10" NPT			24.00	39.50	780

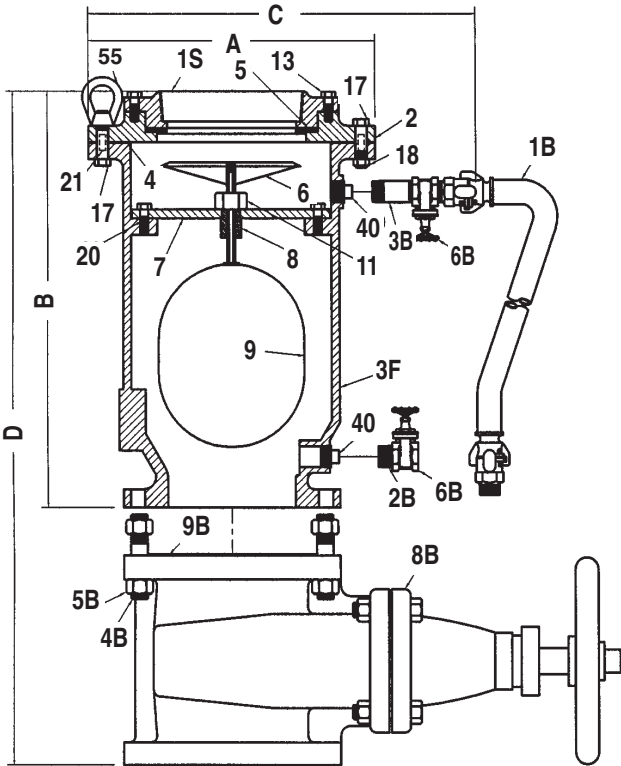

Parts List

ITEM	QTY.	DESCRIPTION	MATERIAL	ASTM
1S	1	TOP	CAST IRON	A126 CL.B
2	1	FLANGE	CAST IRON	A126 CL.B
3F	1	BODY	CAST IRON	A126 CL.B
4	1	FLANGE GASKET	ARMSTRONG N-8092	N/A
5	1	SEAT	BUNA-N RUBBER	D2000
6	1	VALVE&FLOAT ROD	STAINLESS STEEL	A276/A312
7	1	ROD GUIDE SUPPORT	CAST IRON	A126 CL.B
8	1	FLOAT ROD GUIDE	NYLATRON	N/A
9	1	FLOAT	STAINLESS STEEL	A240
11	1	ROD GUIDE NUT	STAINLESS STEEL	A194
13	12	BOLT	STEEL	A307
17	12	FLANGE BOLT	STEEL	A307
18	12	FLANGE NUT	STEEL	A563
20	2	BOLT	STAINLESS STEEL	A193
21	2	FLANGE ALIGN. PIN	HARDENED STEEL	A563
55	2	EYE PIN	STEEL	A563
*40	2	PLUG	CAST IRON	A126 CL.B

OPTIONAL BACK FLUSH COMPONENTS

ITEM	QTY.	DESCRIPTION	MATERIAL	ASTM
*1B	1	HOSE ASSEMBLY	CAD.PLT STEEL&RUBBER	N/A
*2B	1	1" X CL. NIPPLE	STEEL	A312
*3B	1	1" X 3" NIPPLE	STEEL	A312
*4B	8	STUD	STEEL	A307
*5B	16	NUT	STEEL	A563
*6B	2	1" GATE VALVE	CAST IRON	N/A
*8B	1	8" GATE VALVE	CAST IRON	N/A
*9B	1	GASKET	ARMSTRONG N-8092	N/A



Submittal Sheet for Crispin SA Series

1"-2" Air/Vacuum Sewer Valve (SB)

Manufactured in compliance with ANSI/AWWA C512

Date: October, 2001

Specifications

Air and Vacuum Release Valve(s) shall be installed at high points in the main line, or as directed by the engineer. This will permit the release of air as the main is filling, or relieve the vacuum as the main is draining or is under negative pressure.

Valve construction shall be _____" NPT screwed or ANSi Class (125, 250) flanged inlet connection, and shall be cast iron body, top and inlet flange (where required), stainless steel trim and float. The outlet connection shall be cast iron body, top and inlet float (where required), stainless steel trim and float. The outlet shall be _____" NPT screwed.

The valve(s) shall be Crispin Model _____ Air & Vacuum Sewer Valves, as manufactured by Crispin-Multiplex Manufacturing Co., Berwick, PA.

Option: The valve(s) shall be supplied with back flushing attachments so that the interior body can be flushed periodically for proper operation.

Option: The valve(s) shall be a special short body short valve with overall height not to exceed 12 1/4.

Option: A protectop shall be supplied to prevent debris from entering the outlet of the valve.

Option: Where pressures are greater than 300 PSIG, the valve(s) shall be ANSi Class _____ flanged inlet connection, and shall have a (steel, stainless steel, or ductile iron) body, top and inlet flange.

Standard operating pressure for Crispin Air Valves is 20 to 150 PSIG. Please check one of the following if your operating needs differ:

_____ 2 to 40 PSIG _____ 151 to 300 PSIG

* Parts are interchangeable and optional at customer's request.

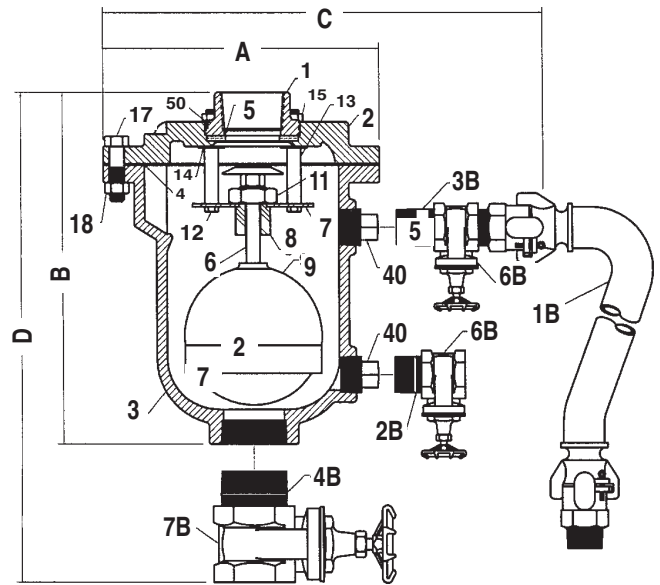

Parts List

ITEM	DESCRIPTION	MATERIAL	ASTM
1	TOP	CAST IRON	A126 CL.B
2	FLANGE	CAST IRON	A126 CL.B
3	BODY	CAST IRON	A126 CL.B
4	FLANGE GASKET	ARMSTRONG N-8092	N/A
5	SEAT	BUNA-N RUBBER	D2000
6	VALVE & FLOAT ROD	STAINLESS STEEL	A582
7	ROD GUIDE STAND	STAINLESS STEEL	A240
8	FLOAT ROD GUIDE	NYLATRON	D5989
9	FLOAT	STAINLESS STEEL	A240
11	ROD GUIDE NUT	STAINLESS STEEL	A194
12	STAND ROD SCREW	STAINLESS STEEL	A193
13	STAND ROD	STAINLESS STEEL	A582
14	STAND ROD GASKET	FIBER	D710
15	STAND ROD NUT	STEEL	A563
17	BOLT	STEEL	A307
18	NUT	STEEL	A563
*40	FLUSH PLUG	CAST IRON	A126 CL.B
50	INTERFERENCE PIN	STAINLESS STEEL	A582

OPTIONAL BACK FLUSH COMPONENTS

*1B	HOSE ASSEMBLY	CAD.PLT STEEL & RUBBER	N/A
*2B	NIPPLE	STEEL	A53
*3B	NIPPLE	STEEL	A53
*4B	NIPPLE	STEEL	A53
*5B	GATE VALVE	BRASS	N/A
*6B	GATE VALVE	BRASS	N/A

Size Specifications

MODEL	INLET SIZE	OUTLET SIZE	A	B	C	D	WHT.
S10AS	2" NPT	1" NPT	10.25	12.25			54
S10ASB	2" NPT	1" NPT			13.75	16.25	66
S20AS	2" NPT	2" NPT	10.25	12.25			54
S20ASB	2" NPT	2" NPT			13.75	16.25	66