

K-FLO

BUTTERFLY VALVES

INSTALLATION AND MAINTENANCE FOR SERIES 47 K-FLO BUTTERFLY VALVES

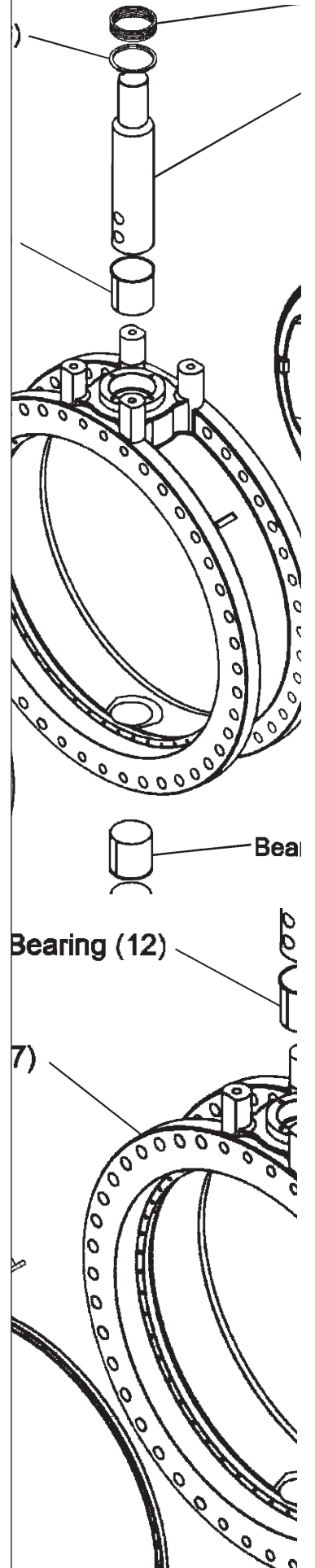
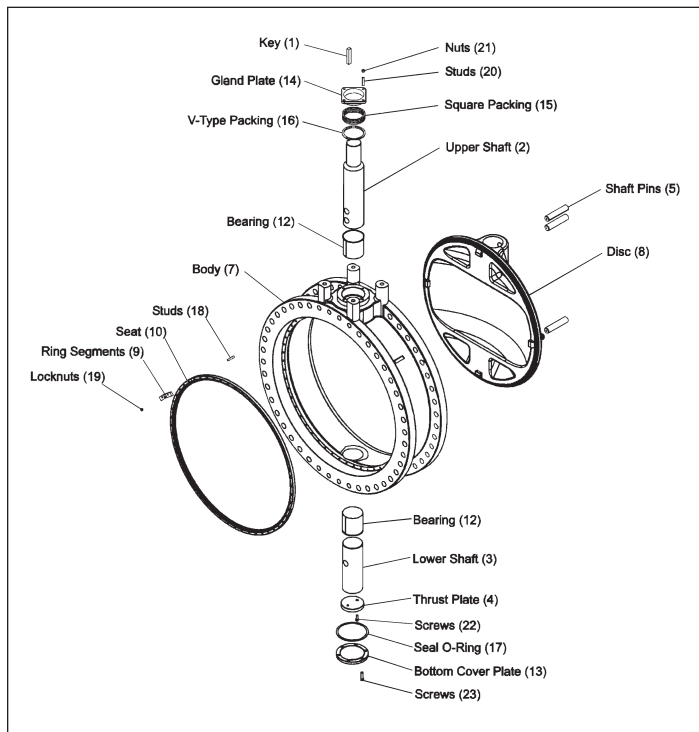

PO Box 411
Berwick PA 18603

800-247-VALV
www.crispinvalve.com

Product Introduction -- K-FLO Series 47: 24"-168"

Instructions

These instructions are intended for personnel who are responsible for the installation, operation and maintenance of your K-FLO AWWA butterfly valve.

Safety Messages

All safety messages herein are flagged with the word Caution, Warning or Danger. These messages must be followed to avoid equipment damage, personal injury or death.

Safety label(s) on the product indicate hazards that can cause equipment damage, personal injury or death. If a safety label becomes difficult to see, or if a label has been removed, please contact Crispin Valve for replacement.

Personnel involved in the installation or maintenance of valves should be constantly alert to the potential emission of process material and take appropriate safety precautions. Always wear suitable protection when dealing with hazardous process materials. Handle valves which have been removed from service with the assumption that process material could be present within the valve.

Inspection

Your AWWA butterfly valve has been packed to provide protection during shipment. Inspect the unit for damage upon arrival and file a carrier claim if damage is apparent.

Parts

Order parts from your local sales representative, or directly from Crispin Valve.

Crispin Valve Service

Crispin service personnel are available to install, maintain and repair all Crispin Valves and products. Crispin also offers customized training programs and consultation services. For more information, contact your local Crispin/K-FLO Valve sales representative or visit our website at www.crispinvalve.com

Table of Contents

Description	A
Flange Requirements	A
Installation Instructions.....	C
Parts Identification	B
Installation Adjustments	C
Maintenance and Repair	D
Lubrication.....	D
Seat Replacement	D
Seat Adjustment.....	D
Shaft Bearing Replacement.....	E
Disc/Stem Replacement	F
Recommended Storage Procedures.....	F
Troubleshooting	G

Description

K-FLO AWWA Butterfly Valves are heavy-duty, rubber seated butterfly valves in full compliance with AWWA C-504 for use in municipal water treatment, power generation, and industrial applications. K-FLO valves utilize bearings that are of the self-lubricating type which provide strength and low friction for easy operation and lifetime service. No special periodic maintenance is necessary.

Maintenance

This valve is assembled using standard SAE fasteners. To service this valve, you should have a full set of combination wrenches, flat tipped screwdrivers, allen wrenches, a torque wrench, sockets, chisels, a hooked tool for removing the packing and a dead blow hammer. Periodic lubrication is not necessary with the basic valve. See the actuator and accessory instructions for any lubrication requirements these assemblies may have.

Flange Requirements

The K-FLO Butterfly Valves are designed for installation between ANSI B16.1 Class 125# flat faced flanges. Mechanical joint valves are designed for use with AWWA C111 end connections. MJ accessories for the pipe used must be supplied by the installing contractor. Class 250 valves can be ordered with either ANSI B16.1 250# drilling, ANSI B16.1 125# drilling or AWWA C111 MJ ends.

K-FLO Series 47--Installation Instructions

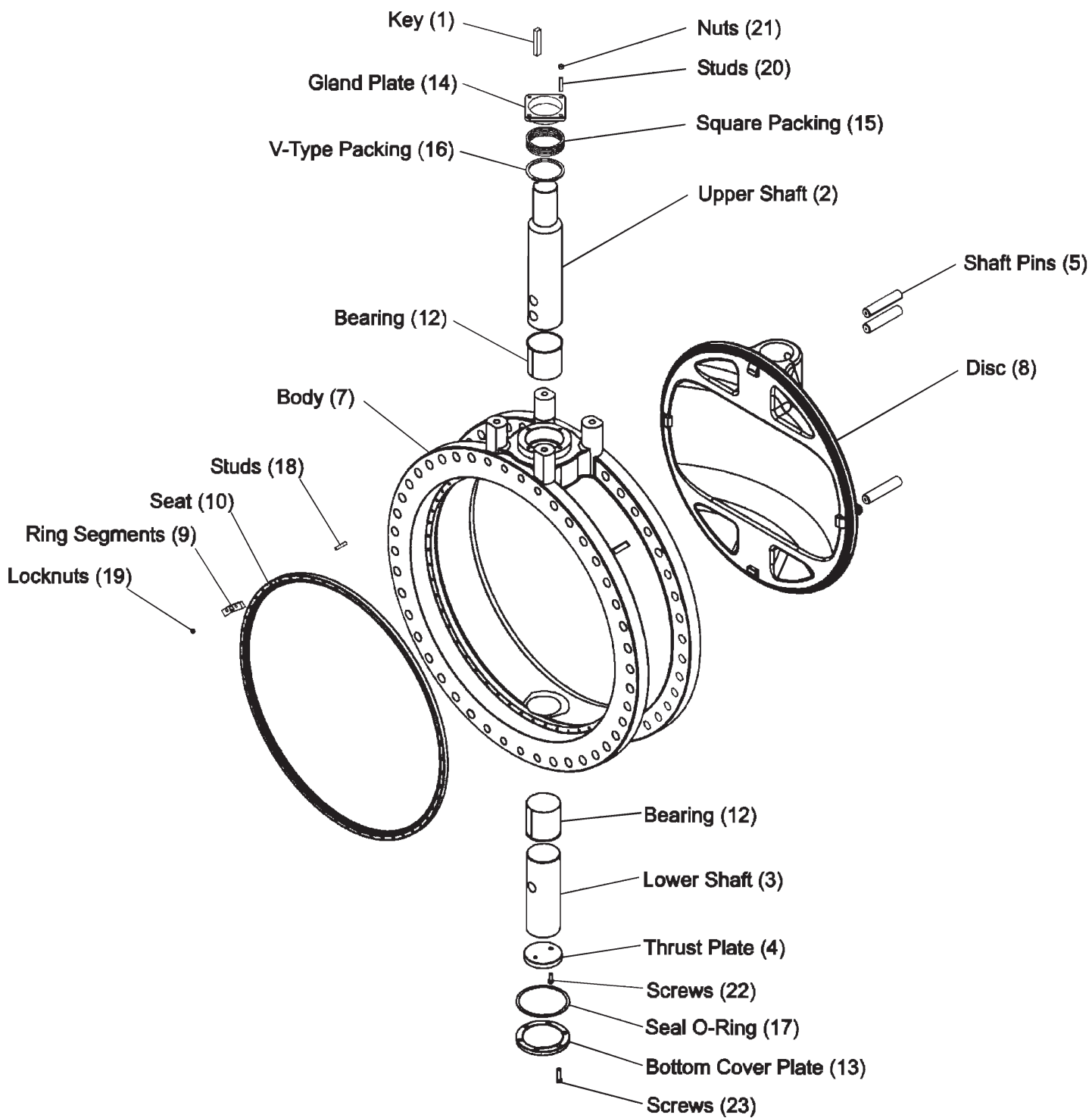

K-FLO Series 47--Installation Instructions

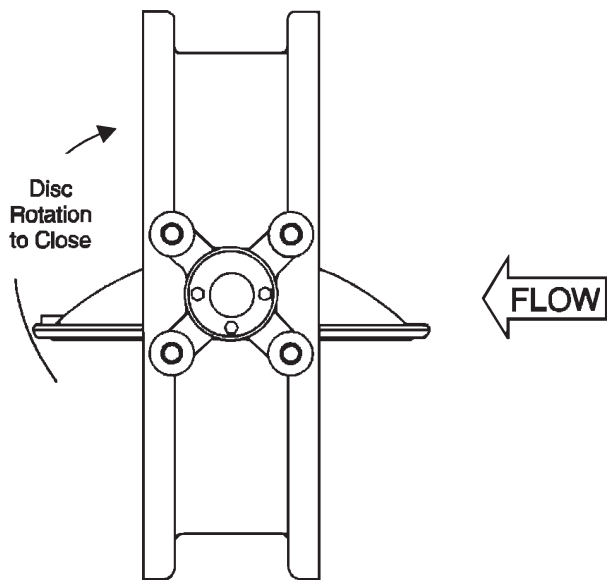

Figure 1--Flow Direction

Installation Instructions

Failure to lift the valve properly may cause damage.

Lift the valve with non-metallic slings fastened around the valve mounting plate, or attach them to bolts or rods run through the flange bolt holes.

Do not fasten lifting devices to the actuator or disc, or through the seat opening in the body.

Note: The Valve disc must be in the closed or nearly closed position, before installation of the valve in the pipeline. This is done to protect the disc seating edge. The valve may be installed with the flow in either direction; however, seat adjustment is facilitated when the flat side of the disc is positioned downstream (see Figure 1).

The valve shaft axis may be either vertical or horizontal. If possible, the valve should be located at least six diameters downstream of all pump, elbows, or tees (see Figure 2).

Installation Adjustments

All Series 47 valves are adjusted and tested at the factory in accordance with AWWA-C-504's latest revision. However, small leaks due to distortion from installation or piping stresses may occur. Such leaks may be stopped by slight tightening (usually a 1/4 turn) of the seat adjusting nut(s) at the leak location (see Figure 4).

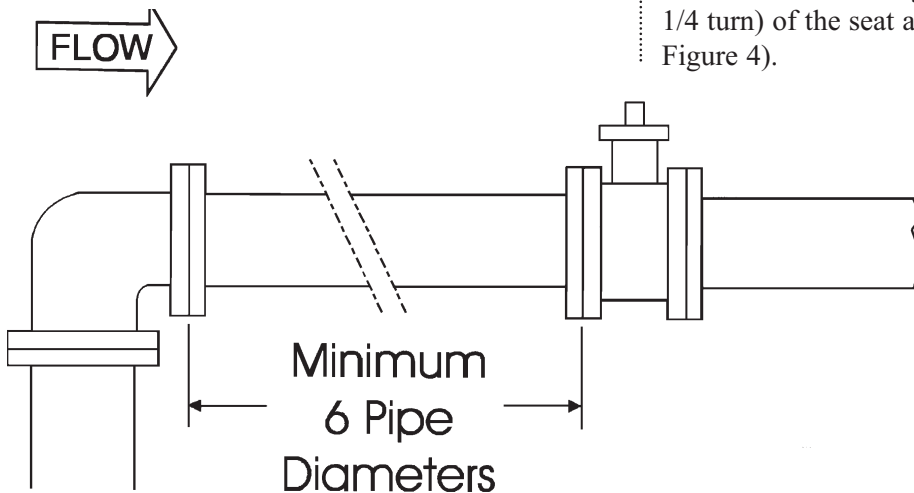

Figure 2--Valve Location

WARNING: Moving Parts from accidental operation of power actuator can cause personal injury or equipment damage. Disconnect and lock out power to actuator before servicing.

WARNING: The valve is a pressure vessel. Good maintenance and practice dictates that the valve must be depressurized prior to performing maintenance. Isolate the valve in the pipeline by closing the valve that is just upstream, and then the valve that is just downstream (in that order) prior to performing maintenance.

Maintenance and Repair

Lubrication:

No routine lubrication is required. The bushings are permanently lubricated. Silicone grease (DOW III or equivalent) is required during seat replacement/adjustment.

Replacement of Shaft Packing

(see Figure 5).

1. Remove the gland nuts (21) and slide the gland plate (14) up along the upper shaft (2)
2. Carefully pry out the old packing rings.
3. Install the new V-Type packing (16).
4. Install new square packing (15), alternating the packing joints on opposite sides of the shaft.
5. Replace the gland plate (14) and gland nuts (21), tightening evenly until the packing is compressed about 1 mm. At this point, you may pressurize the valve and tighten the packing gland until leakage stops.



CAUTION: Do not over-tighten the packing gland nuts. Doing so will increase torque and may cause premature seal failure.

Figure 4--Shaft Adjustment

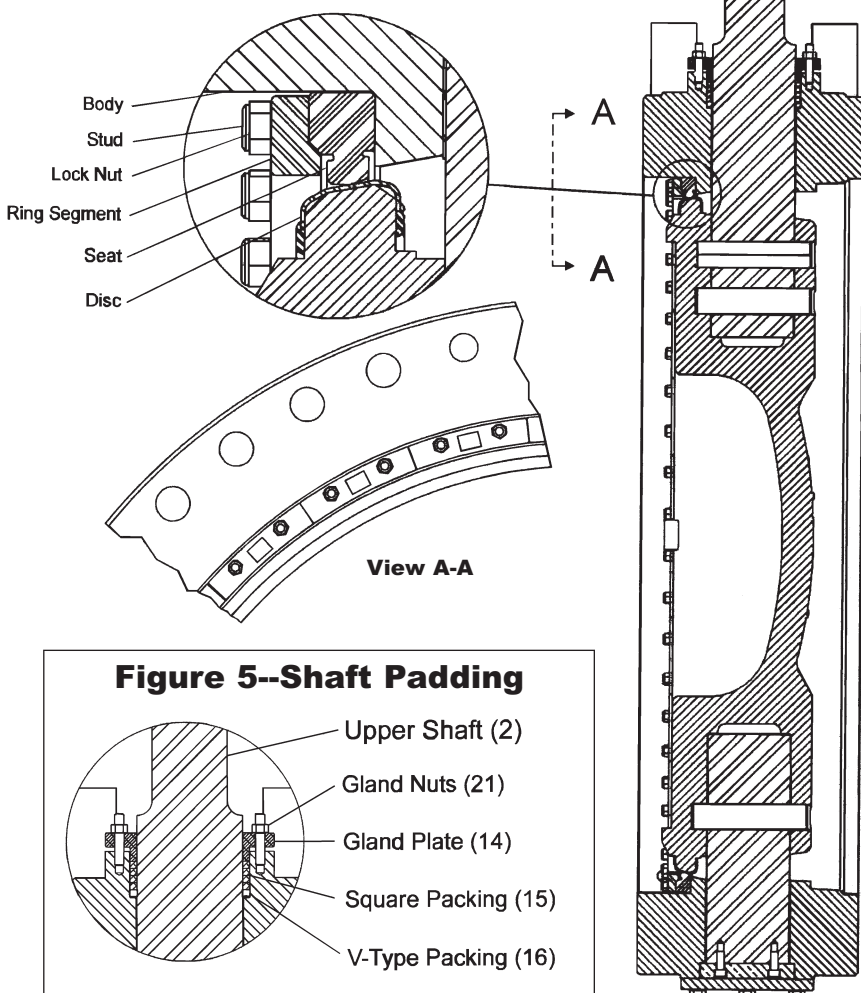

Seat Replacement (see page B)

The seat (10) may be replaced with the valve open or closed and while the valve is in the pipeline.

1. Remove the locknuts (19) and ring-segments (9) from studs (18). A box or open-end wrench is required if the valve is in the pipeline.
2. Pry the old seat (10) off of the studs (18) with a screwdriver or similar tool. Take care not to damage the disc (8) seating edge.
3. Install the replacement seat (10) over the studs (18) with the beveled base toward the ring segments (9).
4. Replace ring segments (9) and install locknuts (19). (See "Seat Adjustment" for adjusting the seat.)

Seat Adjustment (New Seat):

1. Replace seat (10) per "Seat Replacement" procedures.
2. Open the valve disc. Clean and lubricate the seat and seat surface on the disc edge with silicone grease (DOW III or equal).
3. Close valve disc completely.

Figure 5--Shaft Packing

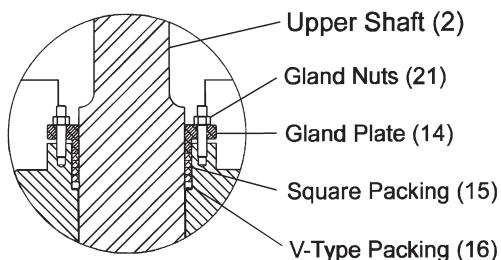

K-FLO Series 47--Maintenance and Repair

Maintenance And Repair Continued

4. Torque all locknuts (19) to 75 in/lbs in a clockwise circular pattern and then to 150 in/lbs.
5. Apply water up to test pressure rating.
6. Note location of leakage. Select one locknut (19) where leakage is occurring and tighten by a 1/4 to 1/3 revolution. Bypass locknuts (19) where there is no leakage. Continue clockwise around the valve, tightening each locknut by a 1/4 to 1/3 revolution where leakage is occurring. Continue this process until the last leak has been stopped. See Table A below for locknut torques.

Seat Adjustment (Existing Seat):

Existing seat with test water pressure.

Note location of leakage. Select locknut (19) where leakage is occurring and tighten by 1/4 to 1/3 revolution, bypassing locknuts (19) where there is no leakage. Continue clockwise around the valve, tightening each locknut by a 1/4 to 1/3 revolution where leakage is occurring. Continue this process until the last leak has been stopped. See Table A below for locknut torques.

**Table A
Locknut Torques**

Valve Pressure Rating	Locknut Torque Range
Class 150B	150-250 in-lbs
Class 250B	150-300 in-lbs

Note: The minimum torque required to achieve a seal at the seat should be used as it lowers valve operating torque and extends seat life.

Shaft Bearing Replacement

Note: The valve must be orientated with the stem's vertical orientation with the disc open in order to remove the bearings.

Top Shaft Bearing

1. Remove actuator. Remove nuts (21), and slide gland plate (14) off the upper shaft (2).
2. Pry out old square packing (15) and remove V-type packing (16).
3. Using a dental pick or similar tool, catch the lip of the bearing (12) and lift while working the bearing out. The bearing may be pushed out from inside the valve to facilitate reaching under the bearing lip.
4. Slide the replacement bearing (12) in place.
5. Replace square packing (15), V-type packing (16) and gland plate (14) as described for replacement of shaft packing.

Bottom Shaft Bearing

1. Remove bottom cover (13) and seal o-ring (17).
2. Remove screws (22) holding the thrust plate (4) to the lower shaft (3).

Maintenance And Repair Continued

Disc/Shaft Replacement

3. Using a dental pick or similar tool, catch the lip of the bearing (12) and lift while working the bearing cut. The bearing may be pushed out from inside the valve to facilitate reaching under the bearing lip.
4. Slide the replacement bearing (12) in place.
5. Fasten thrust plate (4) to the lower shaft (3).
6. Replace seal o-ring (17) with a new one and secure the bottom cover plate (13).

The disc/shaft assembly is drilled and pinned at the factory as a matched set. If replacement of either the disc or stem should be required, Crispin Valve recommends that the valve be returned to the factory for such service.

Recommended Storage Procedures

Long-Term Storage

1. All resilient seated valves shall be stored in the open (unseated) position.
2. All valves with adjustable packing glands should have the packing gland loosened prior to storage.
3. Valves shall be separately packaged in a sealed polyethylene plastic enclosure with a minimum of one package of dessicant inside, dependent upon valve size.
4. Prepared valves shall be warehoused in a clean, dry, indoor facility on concrete or raised racks, with temperature ranging from 35°F to 95°F (2°C to 35°C).
5. Valves shall not be near electric motors or other equipment which may emit Ozone. This can cause deterioration of elastomer components in the valve and actuator.
6. The valves shall be inspected periodically. Replace the dessicant if required, and repair any damage to the polyethylene plastic enclosures.
7. Valves with cylinder operators and controls that are stored for extended periods may be subject to cylinder blow-by caused by permanent distortion of any of the seals. Valves should be operated prior to installation and damaged seals replaced.
8. Valves with electric motor operators shall be stored in accordance with the individual motor manufacture's recommended long-term storage procedures, in addition to Paragraphs 1, 2 and 3 above.
9. All electrical components, if applicable, should be inspected and all electrical contacts cleaned before operation.
10. Valves shall be enclosed in fully sheathed wooden crates or boxes.

Short-Term Storage

1. Valve should be protected from the weather. Avoid exposure to excessive moisture or dirt. Store at temperatures ranging from 35°F to 95°F (2°C to 35°C).

K-FLO Series 47--Troubleshooting

SYMPTOMS	POSSIBLE CAUSE	SUGGESTED REMEDY
Valve opens only a few degrees and stops (it will not open to the full angle desired)	Improper Installation. The valve is improperly aligned.	Loosen the flange bolts. Realign the valve with flanges, and retighten the flange bolts to correct torque per ANSI requirements.
	Mating pipe internal diameter or other obstruction is interfering with disc.	Pipe does not meet standards and spacers may be required. Any pipeline or disc obstruction must be removed.
	Actuator not properly installed	Refer to actuator adjustment.
Leakage past the flange face	Flange bolts are not evenly torqued.	Loosen the flange bolts and tighten the flange bolts to correct torque per ANSI requirements.
	Improper flanges	Refer to "Flange Requirements" on page A.
	Improper flange gaskets	Full face flange gaskets required.
Leakage in the closed position (leakage in the pipeline)	The disc is not closing fully: Actuator is not properly adjusted.	Refer to "Actuator Adjustment" procedures.
	Damaged or improperly aligned valve seat	Follow "Seat Adjustment" procedures on page 5, or replace seat if damaged.
	Line pressure exceeds valve's working pressure	Reduce line pressure to valve working pressure.
	Damaged valve disc	Return valve to factory for disc/ stem replacement.
Leakage at the valve stem	Packing failure	<ol style="list-style-type: none"> 1. Fully open and close the valve 3 times. 2. Refer to "Replacement of Shaft Packing" on page F.
Water Hammer	The valve is closing too quickly.	Turn actuator slower.
Excessively high torque	Obstruction in the pipeline	Remove valve from pipeline and remove obstruction.
	Valve shaft or disc bent	Return valve to factory for disc/shaft replacement (check for water hammer or freezing of line material).
	Scale buildup on shaft or seat	Open and close the valve several times. Operate the valve at least once a month. Check the valve seat for deterioration.