



**KNIFE GATE  
VALVES  
DN 50 - DN 4000**

**JASH - SCHÜTTE - WECO**

**CUTTING EDGE KNIFE GATE VALVE TECHNOLOGY**

- Water & waste water
- Sea water
- Storm water
- Pulp & paper
- Petrochemicals
- Ash handling



*DN 2000, Bi-directional, PN 10 rated bonnetless tandem spindle electrically operated knife gate valve*

**JASH ENGINEERING LIMITED***Over 65 years of tradition, innovation & growth*

Jash Engineering Ltd. is an ISO 9001-2008 certified company manufacturing a wide range of equipments for the water and waste water industry. Established in the year 1948, Jash today offers the most diversified product portfolio for the water industry comprising of water control gates, fine & coarse screening equipments, knife gate valves, water hammer control valves, energy dissipating valves, Archimedean screw pumps, hydropower screw generator and treatment plant process equipments like degritters, clarifiers, clarifloculators, aerators, mixers, DAF units and decanters.

Jash presently exports its products to over 25 countries like USA, Canada, Britain, France, Germany, Belgium, Norway, Sweden, Kazakhstan, Turkey, Kuwait, Saudi Arabia, Jordan, Oman, Bahrain, UAE, Iraq, Israel, Singapore, Malaysia, Thailand, Indonesia, Vietnam, Hong Kong, Philippines, New Zealand etc.

Jash offers its range of products under various brands such as Jash, Jash Schütte, Jash Weco, Jash Sureseal, Jash FSM, Jash Mahr Maschinenbau, Jash Stealth, Jash Rehart and Shivpad. Today, Jash is acknowledged as an industry leader for most of its product offerings and is known as a company that is able to innovate and introduce various new technologies in the market.

**Schütte****JASH - SCHÜTTE - WECO KNIFE GATE VALVES***Cutting edge knife gate valve technology for diversified applications*

Jash entered the knife gate valve business in the year 1995 with the introduction of ZFT series knife gate valves produced in technical collaboration with Schütte group, Germany. The ZFT series valves catered to bulk solids handling application as well as for solid-liquid mixes / slurries application. Over a period of time the ZFT series valves were modified and a new series named "ZFI" was developed for the world market.

The ZFT / ZFI series valves were non bonneted valves with gland packing needing high torque for operation and were in principle similar to most of the valves offered by many manufacturers world over. To overcome the technical limitations of ZFT / ZFI series valves, Jash entered in collaboration with WECO Armaturen GmbH, Germany to introduce their "MONO" knife gate valves which are most ideal for liquid application.

The MONO valve design offers unique features such as glandless valve, bonneted body, very low operating torque and easy changeover from resilient seated valve to metal seated valve & vice versa. These features make the MONO valve design distinctly different and superior in comparison to most of the conventional knife gate valves. With the introduction of the AWWA C520-10 standard for knife gate valves in the year 2010, Jash developed the MONO-A & MONO-T variants in the year 2011 to comply with the requirements of this new AWWA standard as well as TAPPI standard. Another variant named "MONO-C" was then introduced in the year 2014 to cater to low pressure requirement application of the waste water treatment industry in a cost effective manner.

*As a result of these developments, Jash presently has one of the most diversified knife gate valves range in the world market to suit the varied requirements of the industry.*

## MANUFACTURING FACILITIES



*Knife gate valve plant, Indore*



*Sluice gate plant, Indore*



*Cast iron foundry, Indore*



*Fabricated products plant, Indore*

Jash employs over 100 engineers and 500 workers at its various facilities and offices located in India, USA and Austria. Jash had annual sales of over USD 20 Million in the year 2014 and plans to cross USD 50 Million in sales by 2018 through growth and acquisitions. To meet this target Jash has invested heavily in various infrastructure to ensure that it has one of the most modern and extensive facilities amongst water and waste water equipment manufacturers worldwide.

With its three manufacturing plants based around the city of Indore in Central India, one manufacturing facility at Chennai in South India and one manufacturing facility in Vienna, Austria, Jash has over 450,000 sq feet of manufacturing area under cranes to manufacture its entire range of products.

Jash has an in-house Cast iron foundry which is geared to make Grey iron castings weighing upto 18 tonnes single piece. Jash together with Schütte group, Germany has invested in an alloy steel casting foundry to produce valve and other alloy castings weighing upto 1000 kgs.

The machine shop is equipped with conventional as well as CNC machines capable of machining jobs of size 7000x3450x1000mm (LxBxH). Jash has an in-house machining facility to machine knife gate valves upto DN 4000 size.

Profiled cutting of Stainless steel plates upto 100 mm thickness is done using CNC water jet cutting. Hydraulic shear and press brake are used for normal cutting & bending.

The testing shop is equipped to conduct leakage and hydrostatic tests of valves upto DN 4000 size.

All welding activity is done using certified welders and processes as per section IX of AWS-D1.6/D1.6M-2007. Post manufacturing activities like shot blasting, bath pickling and airless spray painting are done under environmentally safe conditions. Jash has an in-house fusion bonded painting facility and can offer NSF-61 certified paint on the valves. The final product assembly is done in isolated areas to carry out the assembly in a clean environment.



*Export plant, SEZ, Pithampur*

## IN HOUSE CAPABILITIES TO MANUFACTURE VALVES UPTO DN 4000 SIZE



*Cast iron foundry*



*Shearing & bending machine*



*Water jet cutting machine*



*Large CNC milling machine*



*Large floor boring machine*



*Valve machine shop at Indore plant*



*Valve assembly at SEZ plant*



*Valve assembly at Indore plant*



*Valve testing area*



*Positive material identification (PMI)*



*Hardness testing machine*



*Bath pickling 2.5 x 2 x 7.5 m*



*Shot blasting 6 x 6 x 24 m*



*Fusion bonded painting*

## SEALING CONFIGURATIONS

The performance & lifetime cost (inclusive of maintenance cost and replacement cost) of a knife gate valve is dependent on the type of sealing configuration selected. The varied sealing configurations offered by the industry and their relative advantage / disadvantage is given below so as to enable clients understand the best option for their particular application.

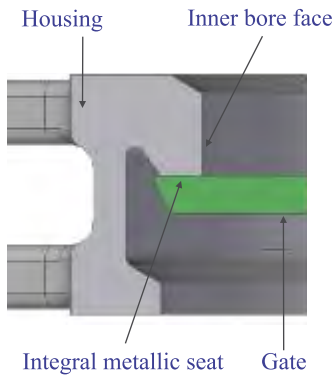

Figure A

### (1) Integral metal seated:

- **Description:** In this configuration a seat face is provided on the edge of the inner bore face of valve housing and this raised seat face acts as an integral metallic seat.
- **Application:** Valve with this type of sealing configuration is suitable for isolation requirements where media has high contents of solid and where slight leakage is not critical. This type of sealing configuration is also preferred for applications where temperature is greater than 250° C.
- **Advantage:** Initial cost of valve with this seal configuration is the lowest and also seat leakage rate is slightly lower when compared to non integral metal seated valves.
- **Disadvantage:** In this type of sealing configuration the whole housing needs to be replaced when the valve seat face gets damaged or worn out due to erosion of inner bore face of valve on account of material flow. Also it is not possible to re-assemble the valve using replacement housing at site and so the whole valve has to be replaced at a high replacement cost in future.

This sealing configuration is available only in "ZFI-M" variant of "ZFI" series valves.

**Figure A:** Cross sectional view of integral metal seated "ZFI-M" valve

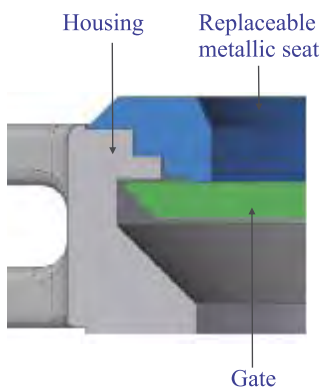

Figure B

### (2) Non integral metal seated:

- **Description:** In this configuration a replaceable metallic seat is provided and this replaceable metallic seat is bolted to the valve housing by fasteners.
- **Application:** Valve with this type of sealing configuration is suitable for isolation requirements where media has high contents of abrasive or erosive solids and where slight leakage is not critical. This type of sealing configuration cannot be used in applications where temperature is greater than 250° C.
- **Advantage:** There is no need to replace the complete valve in event of valve seat damage or in event of erosion of inner bore face of valve due to material flow. The replaceable metallic seat can be changed easily at the site using the same valve housing without dismantling other valve parts.
- **Disadvantage:** Initial cost of valve with this sealing configuration is higher than integral metal seated valves and valves with replaceable metallic seat may have slightly higher seat leakage rate in comparison to integral metal seated valve.

**Figure B:** Cross sectional view of non integral metal seated "ZFI-MRR" valve

**Figure C:** Cross sectional view of non integral metal seated "MONO" valve

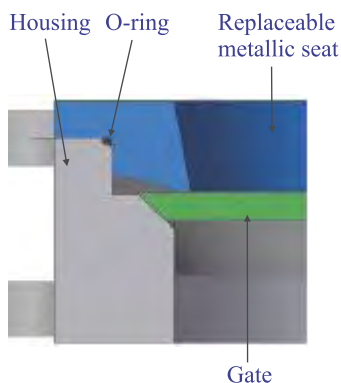

Figure C

### (3) Resilient seat retained with replaceable metallic seat retainer ring:

- **Description:** In this configuration a replaceable resilient seat is retained within a replaceable metallic seat retainer ring bolted to the valve housing by fasteners.
- **Application:** Valve with this type of sealing configuration is suitable for isolation requirements needing leak tight shut-off and where media has high contents of abrasive or erosive solids. This type of sealing configuration cannot be used in applications where temperature is greater than 250°C.
- **Advantage:** There is no need to replace the complete valve in event of damage to the replaceable resilient seat or in case of erosion of inner bore face of valve due to material flow. The replaceable resilient seat as well as the replaceable metallic seat retainer ring can be changed at the site using the same valve housing without dismantling other valve parts. Replacement of these parts do not need any expertise and is very easy.
- **Disadvantage:** Initial cost of valve with this sealing configuration is the highest.

**Figure D:** Cross sectional view of non integral resilient seated "ZFI-SRR" valve

**Figure E:** Cross sectional view of non integral resilient seated "MONO" valve

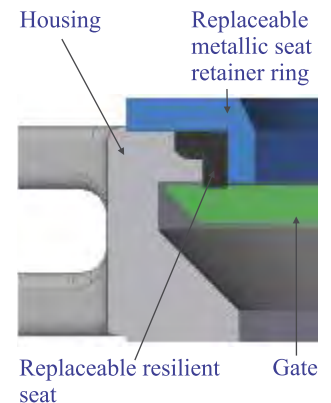

**Figure D**

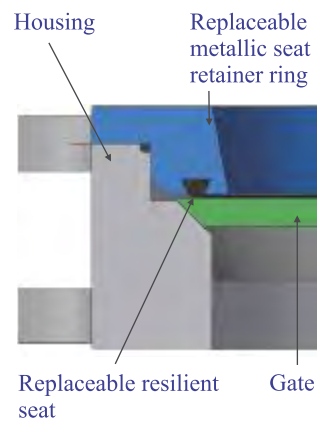

**Figure E**

### (4) Resilient seat retained by replaceable metallic seat retainer strip / band :

- **Description:** In this configuration a replaceable resilient seat is retained in the housing using a thin 1 - 2 mm thick stainless steel metallic band / strip located on the inner face of the valve. The seat remains in place because of outward radial pressure exerted by the thin metal strip / band located on the inner bore face.
- **Application:** Valve with this type of sealing configuration is suitable for isolation requirements needing leak tight shut-off. This type of seating configuration cannot be used in applications where temperature is greater than 250°C.
- **Advantage:** Valves with this sealing configuration are less expensive than valves having replaceable resilient seat encased in replaceable metallic seat retainer ring. In this case also there is no need to replace the complete valve in event of damage to the resilient seat.
- **Disadvantage:** The replacement of seat as well as the metallic strip / band needs disassembly of complete valve and special expertise are required in re-fixing the metallic strip / band. Also whenever the resilient seat has to be replaced then the metallic strip / band used to retain the resilient seal have to be replaced as well. So replacement of seat when retained by metallic strip / strip is not as easy as in case of resilient seat retained by a retainer ring. More ever in case of abrasive or erosive media, the thin metallic band/strip located on the inner bore face and in path of flow will be subjected to erosion and so may be required to be frequently replaced irrespective of whether the resilient seat is required to be replaced or not. In worst case scenario, if the inner bore of the valve housing gets eroded on account of material flow, then the whole valve needs to be replaced.

This sealing configuration is available only in "ZFI-S" variant of "ZFI" series valves.

**Figure F:** Cross sectional view of non integral resilient seated "ZFI-S" valve

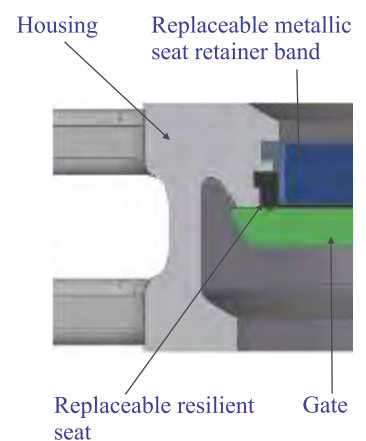

**Figure F**

*In addition to above sealing configurations, Jash also offers customized sealing arrangement to suit clients requirement and application.*

## JASH KNIFE GATE VALVE SELECTION CHART

Models	MONO-A	MONO-C	MONO-T	ZFI-M	ZFI-S	ZFI-SRR
<b>Size range (mm)</b>	DN 80-600	DN 80-600	DN 80-600	DN 50-4000	DN 50-600	DN 50-4000
<b>Suitable pipe flanges</b>	ANSI B16.5 150lb / DIN PN 10 / IS 1538 / BS EN 1092 / BS 4504 MONO-A & MONO-T series valves can also be offered with PN 16 flange drilling					
<b>End style</b>						
Semi / two lugged	X	X	X	*	✓	*
Full lugged	✓	✓	✓	X	X	X
Full flanged	X	X	X	*	X	*
<b>Sealing configuration</b>						
Integral metal seated	X	X	X	✓	X	X
Non integral metal seated	✓	✓	✓	X	X	X
Resilient seat retained with replaceable metallic retainer ring	✓	✓	✓	X	X	✓
Resilient seat retained by metallic band	X	X	X	X	✓	X
<b>Design features</b>						
Single piece bonnet design	✓	✓	**	X	X	X
Bolted bonnet design	X	X	**	X	X	X
Glandless design	✓	✓	✓	X	X	X
Very low operating torque	✓	✓	✓	X	X	X
Upside down installation in pipeline	✓	✓	✓	X	X	X
Unidirectional	✓	✓	✓	✓	✓	✓
Small bidirectional	✓	✓	✓	X	X	X
Full bidirectional	X	X	X	X	X	X
End of line / terminal position	✓	✓	✓	✓	✓	✓
<b>Compliance to standard</b>						
AWWA C520-10	✓	X	✓	X	X	X
MSS SP-81	X	X	X	✓	✓	✓
TAPPI	X	X	✓	X	X	X
<b>Allowable leakage</b>						
Zero leakage (in resilient seated valves)	✓	✓	✓	X	✓	✓
40cc / min / inch (in metal seated valves)***	✓	✓	✓	✓	✓	✓

### Rated working pressure in bars

Models	MONO-A	MONO-C	MONO-T	ZFI-M/ ZFI-S/ ZFI-SRR#		
<b>Size range (mm)</b>	DN 80-600	DN 80-600	DN 80-600	DN 50-300	DN 350-600	DN 650-1200
<b>Body material</b>						
Cast iron	NA	5	NA	10	6	3
Ductile iron	10 & 16	NA	NA	10	6	3
Cast carbon steel	NA	NA	NA	10	6	3
Cast stainless steel	NA	NA	10 & 16	10	6	3

- (✓) : Available as standard  
 (X) : Not available as standard, for additional details please contact Jash  
 (\*) : Semi / two lugged upto DN 600 & full flanged above DN 600  
 (\*\*) : Single piece upto DN 150, two piece split design above DN 150  
 (\*\*\*) : Applicable for sizes DN 50 to DN 600, as agreed mutually for higher sizes  
 (#) : For these models higher working pressure than stated below can be offered upon request  
 (NA) : Not applicable



## "MONO" SERIES KNIFE GATE VALVES

The MONO series knife gate valves are manufactured under collaboration with WECO Armaturen GmbH, Germany. The MONO series valves are bonneted, gland less, very low operating torque knife gate valves for leak tight application in resilient seated valves from the preferred direction of flow at full applicable pressure and at low pressure from non preferred direction of flow. Metal seated valves offer leakage within permissible limits as per AWWA C520-10 standard.

These can be installed in any position (vertical, horizontal, inclined) including in upside down position in clear liquid application. The MONO series knife gate valves are ideal for liquid media and can also be used for solid liquid mixes and are provided with full bore opening which do not restrict the flow in pipeline.

This unique design of MONO series valves is patented by WECO Armaturen GmbH, Germany as per details given at the bottom of the page.

### Salient features of MONO series knife gate valves:

- A lug type design of sleek construction having low face to face distance for mounting in compact installations.
- Varied sealing configurations such as resilient seat retained with replaceable metallic seat retainer ring and non integral metal seated.
- Resilient seated valves are offered with replaceable resilient "O" ring seal housed in replaceable metallic seat retainer ring for easy and quick replacement at site.
- Metal seated valves are offered with replaceable metallic seat for easy and quick replacement at site.
- Easy & quick conversion of resilient seated valve to metal seated valve & vice versa by replacing the metallic retainer ring.
- Floating gate design ensures that the gate does not slide on the seat during opening & closing. The gate is pushed up by wedging at the last millimeters of the closing process so as to achieve face sealing with the full periphery of seat. As a result of this feature the life of resilient seat is much more than any conventional knife gate valve.
- Gate having beveled knife edge at the periphery to cut through solid particles settled at bottom of body and achieve full closure.
- Glandless design which eliminates the possibility of any leakage from the gland packing area.
- Provided with purging holes to purge the material retained in valve housing.
- Very low valve operating torque compared to conventional knife gate valves. Operating torque as low as 1 Kg-m enabling easy and fast operation using single finger up to DN 300 size.
- Rising spindle or non rising spindle as per requirement.
- Manual / Pneumatic / Electric / Hydraulic operation as per requirement.

Part No.	Description
1.	O-ring
2.	Thrust washer
3.	Sealing nut
4.	Connecting pipe
5.	Stem nut
6.	Stem

Patent no. 12/39960 for USA, Canada, Europe, Asia

Patent no. IN 187285 for India



Full lugged design valve

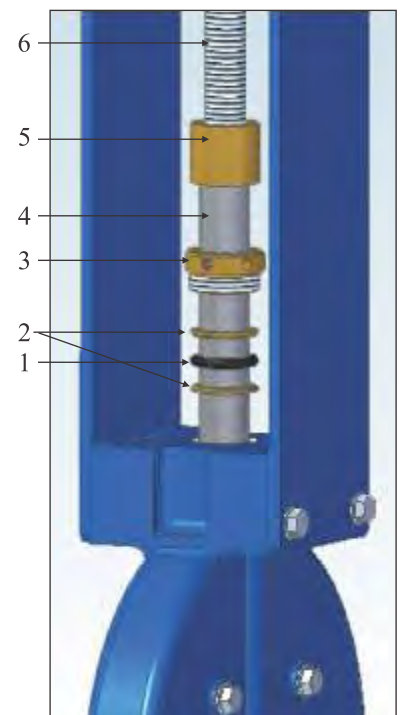

View showing glandless design feature

The MONO series valves are offered in various variants as under:

- **MONO-A:** Ductile iron construction valve for requirements of high pressure rating of PN 10 & PN 16. Valves are offered with full lugged design for end of line mounting.
- **MONO-C:** Cast iron construction valve for requirements of low pressure upto 5 bars. Valves up to DN 300 are offered with semi lugged design for mounting between flanges and valves above DN 300 are offered with full lugged design for end of line mounting.
- **MONO-T:** Cast stainless steel construction valve for requirements of high pressure rating of PN 10 & PN 16. Valves are offered with full lugged design for end of line mounting.

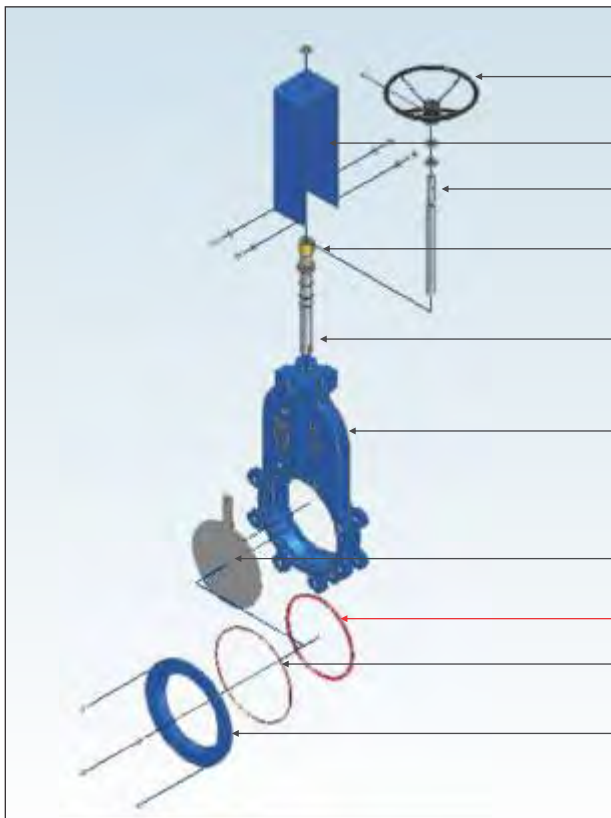

*Exploded view of resilient seated MONO series valves*

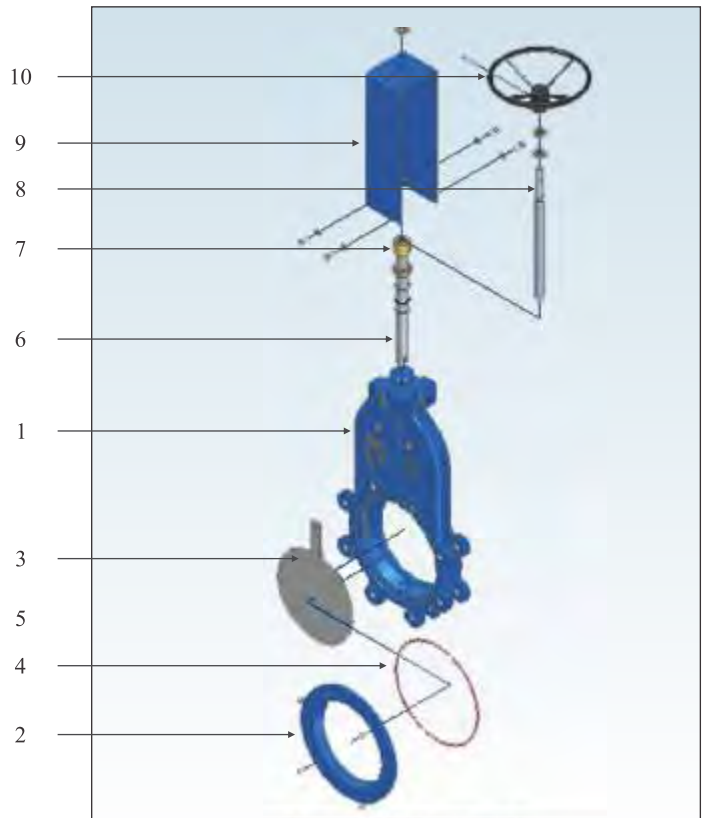

*Exploded view of metal seated MONO series valves*

Part No.	Description
1	Housing
2	Seat retainer ring
3	Gate
4	Gasket
5	Resilient seat
6	Connecting pipe
7	Stem nut
8	Stem
9	Supporting bracket
10	Hand wheel



*Very low operating torque compared to conventional knife gate valves*

## “MONO-A” KNIFE GATE VALVES

The MONO-A variant is a bonneted, full lugged, glandless valve in Ductile iron construction complying with AWWA C520-10 standard. Full lug design enable end of line mounting without the need of additional flange. MONO-A variant is having a single piece design up to DN 600 and split body design for higher sized valves.

### Standard technical specifications:

Manufacturing standard	-	As per AWWA C520-10 standard
Lug / flange provision	-	Full lugged up to DN 600
Flange drilling	-	Suitable for DIN PN 10 / PN 16 / IS 1538 / BS 4504 / BS EN 1092 as well as ANSI B16.5 150lb
Flange to flange distance	-	As per AWWA C520-10 / MSS SP-81
Sealing configuration	-	Resilient seat retained with replaceable metallic seat retainer ring as standard, metal seated optional
Pressure rating	-	PN 10 (150 psig) / PN 16 (240 psig) rated up to DN 600
Nominal size	-	DN 80 – DN 600 as standard, higher sizes on request

### Material of construction options for major components:

Housing	-	Ductile iron as per ASTM A 536 Grade 65-45-12 or BS2789 Grade 400-15 or GGG40 as per DIN 1693-1/2
Gate	-	Stainless steel ASTM A 240 Grade 304 / 316 & duplex / super duplex
Seat retainer ring	-	Ductile iron as per ASTM A 536 Grade 65-45-12 or BS2789 Grade 400-15 or GGG40 as per DIN 1693-1/2
Resilient seat	-	EPDM (NSF-61 certified) / VITON / NBR
Stem	-	Stainless steel ASTM A 276 Grade 304 / 316

Materials other than those stated above can also be offered on request.

### Painting:

External	-	Fusion bonded epoxy or epoxy painted depending upon size & client requirement only on all non-stainless steel parts Total dry film thickness maintained 250 microns minimum
----------	---	--

### Testing:

Testing pressure	-	Refer table below
Leakage criterion	-	Zero leakage as per AWWA C520-10 for resilient seated valves 40 cc / min / inch as per AWWA C520-10 for metal seated valves

All valves are tested prior to shipping in line with details mentioned in table below.

Size	Body test		High pressure seat test (preferred direction of flow)		Low pressure seat test (preferred direction of flow)	High pressure seat test (non-preferred direction of flow)	Low pressure seat test (non-preferred direction of flow)
	PN 10	PN 16	PN 10	PN 16			
DN 80	15 Bar	24 Bar	10 Bar	16 Bar	0.34 Bar	10 Bar	0.34 Bar
DN 100	15 Bar	24 Bar	10 Bar	16 Bar	0.34 Bar	10 Bar	0.34 Bar
DN 150	15 Bar	24 Bar	10 Bar	16 Bar	0.34 Bar	8 Bar	0.34 Bar
DN 200	15 Bar	24 Bar	10 Bar	16 Bar	0.34 Bar	6 Bar	0.34 Bar
DN 250	15 Bar	24 Bar	10 Bar	16 Bar	0.34 Bar	4 Bar	0.34 Bar
DN 300	15 Bar	24 Bar	10 Bar	16 Bar	0.34 Bar	3 Bar	0.34 Bar
DN 350	15 Bar	24 Bar	10 Bar	16 Bar	0.34 Bar	2 Bar	0.34 Bar
DN 400	15 Bar	24 Bar	10 Bar	16 Bar	0.34 Bar	2 Bar	0.34 Bar
DN 450	15 Bar	24 Bar	10 Bar	16 Bar	0.34 Bar	2 Bar	0.34 Bar
DN 500	15 Bar	24 Bar	10 Bar	16 Bar	0.34 Bar	1.5 Bar	0.34 Bar
DN 600	15 Bar	24 Bar	10 Bar	16 Bar	0.34 Bar	1.5 Bar	0.34 Bar



Full lugged design valve

## "MONO-C" KNIFE GATE VALVES



Semi lugged design valve

The MONO-C variant is a bonneted, gland less valve in Cast iron construction designed for low pressure requirements. MONO-C variant is having a single piece design up to DN 600 and split body design for higher sized valves.

### Standard technical specifications:

Manufacturing standard	- Generally complying with AWWA C520-10
Lug / flange provision	- Full lugged / semi lugged up to DN 300, full lugged above DN 300.
Flange drilling	- Suitable for DIN PN 10 / IS 1538 / BS 4504 /BS EN 1092 as well as ANSI B16.5 150lb
Flange to flange distance	- As per MSS SP-81
Sealing configuration	- Resilient seat retained with replaceable metallic seat retainer ring as standard, metal seated optional
Pressure rating	- 5 Bar (75 psig) up to DN 600
Nominal size	- DN 80 - DN 600 as standard, higher sizes on request

### Material of construction options for major components:

Housing	- Cast iron as per ASTM A 126 Grade Class B / Cast iron FG 260
Gate	- Stainless steel ASTM A 240 Grade 304 / 316
Seat retainer ring	- Cast iron as per ASTM A 126 Grade Class B / Cast iron FG 260
Resilient seat	- EPDM / VITON / NBR
Stem	- Stainless steel ASTM A 276 Grade 304 / 316

Materials other than those stated above can also be offered on request.

### Painting:

External	- Fusion bonded epoxy or epoxy painted depending upon size & client requirement only on all non-stainless steel parts Total dry film thickness maintained 250 microns minimum
----------	--

### Testing:

Testing pressure	- Refer table below
Leakage criterion	- Zero leakage as per AWWA C520-10 for resilient seated valves - 40 cc / min / inch as per AWWA C520-10 for metal seated valves

All valves are tested prior to shipping in line with details mentioned in table below.

Size	Body test	High pressure seat test (preferred direction of flow)	Low pressure seat test (preferred direction of flow)	High pressure seat test (non-preferred direction of flow)	Low pressure seat test (non-preferred direction of flow)
DN 80	7 Bar	5 Bar	0.34 Bar	5 Bar	0.34 Bar
DN 100	7 Bar	5 Bar	0.34 Bar	5 Bar	0.34 Bar
DN 150	7 Bar	5 Bar	0.34 Bar	5 Bar	0.34 Bar
DN 200	7 Bar	5 Bar	0.34 Bar	5 Bar	0.34 Bar
DN 250	7 Bar	5 Bar	0.34 Bar	4 Bar	0.34 Bar
DN 300	7 Bar	5 Bar	0.34 Bar	3 Bar	0.34 Bar
DN 350	7 Bar	5 Bar	0.34 Bar	2 Bar	0.34 Bar
DN 400	7 Bar	5 Bar	0.34 Bar	2 Bar	0.34 Bar
DN 450	7 Bar	5 Bar	0.34 Bar	2 Bar	0.34 Bar
DN 500	7 Bar	5 Bar	0.34 Bar	1.5 Bar	0.34 Bar
DN 600	7 Bar	5 Bar	0.34 Bar	1.5 Bar	0.34 Bar

## “MONO-T” KNIFE GATE VALVES

The MONO-T variant is a bonneted, full lugged, glandless valve in Cast stainless steel construction complying with AWWA C520-10 and TAPPI standard. MONO-T variant is having a single piece design up to DN150 and split body design above DN150.

### Standard technical specifications:

Manufacturing standard	-	As per AWWA C520-10 / TAPPI standard.
Lug / flange provision	-	Full lugged up to DN 600
Flange drilling	-	Suitable for DIN PN 10 / PN 16 / IS 1538 / BS 4504 / BS EN 1092 as well as ANSI B16.5 150lb
Flange to flange distance	-	As per AWWA C520-10 / MSS SP-81
Sealing configuration	-	Resilient seat retained with replaceable metallic seat retainer ring as standard, metal seated optional
Pressure rating	-	PN 10 (150 psig) / PN 16 (240 psig) upto DN 600
Nominal size	-	DN 80 – DN 600 as standard, higher sizes on request

### Material of construction options for major components:

Housing duplex	-	Cast stainless steel ASTM A 351 Grade CF: 8 / CF: 8M / super duplex
Gate	-	Stainless steel ASTM A 240 Grade 304 / 316 & duplex / super duplex
Seat retainer ring	-	Cast stainless steel ASTM A 351 Grade CF: 8 / CF: 8M & duplex / super duplex
Resilient seat	-	EPDM / VITON / NBR
Stem	-	Stainless steel ASTM A 276 Grade 304 / 316

Materials other than those stated above can also be offered on request.

### Painting:

External	-	Fusion bonded epoxy or epoxy painted depending upon size & client requirement only on all non-stainless steel parts Total dry film thickness maintained 250 microns minimum
----------	---	--

### Testing:

Testing pressure	-	Refer table below
Leakage criterion	-	Zero leakage as per AWWA C520-10 for resilient seated valves 40 cc / min / inch as per AWWA C520-10 for metal seated valves

All valves are tested prior to shipping in line with details mentioned in table below.

Size	Body test		High pressure seat test (preferred direction of flow)		Low pressure seat test (preferred direction of flow)	High pressure seat test (non-preferred direction of flow)		Low pressure seat test (non-preferred direction of flow)
	PN 10	PN 16	PN 10	PN 16				
DN 80	15 Bar	24 Bar	10 Bar	16 Bar	0.34 Bar	10 Bar	0.34 Bar	
DN 100	15 Bar	24 Bar	10 Bar	16 Bar	0.34 Bar	10 Bar	0.34 Bar	
DN 150	15 Bar	24 Bar	10 Bar	16 Bar	0.34 Bar	8 Bar	0.34 Bar	
DN 200	15 Bar	24 Bar	10 Bar	16 Bar	0.34 Bar	6 Bar	0.34 Bar	
DN 250	15 Bar	24 Bar	10 Bar	16 Bar	0.34 Bar	4 Bar	0.34 Bar	
DN 300	15 Bar	24 Bar	10 Bar	16 Bar	0.34 Bar	3 Bar	0.34 Bar	
DN 350	15 Bar	24 Bar	10 Bar	16 Bar	0.34 Bar	2 Bar	0.34 Bar	
DN 400	15 Bar	24 Bar	10 Bar	16 Bar	0.34 Bar	2 Bar	0.34 Bar	
DN 450	15 Bar	24 Bar	10 Bar	16 Bar	0.34 Bar	2 Bar	0.34 Bar	
DN 500	15 Bar	24 Bar	10 Bar	16 Bar	0.34 Bar	1.5 Bar	0.34 Bar	
DN 600	15 Bar	24 Bar	10 Bar	16 Bar	0.34 Bar	1.5 Bar	0.34 Bar	



Full lugged valve

**"MONO-A / MONO-T / MONO-C" KNIFE GATE VALVES- DIMENSIONAL DETAILS UPTO DN 600**

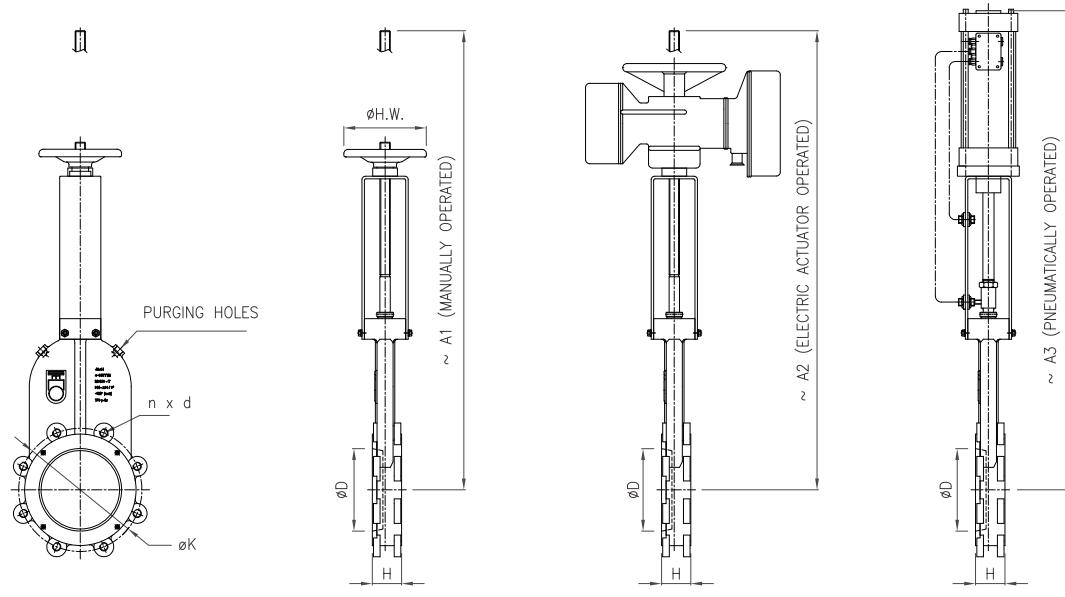

DN	Flange drilling	ØK	n x d	ØD	~A1	~A2	~A3	~H	~ØH.W.
80	PN 10	160	8 x M16	80	600	600	665	51	205
	PN 16	160	8 x M16						
	ANSI B16.5 150lb	152.5	4 x 5/8"						
100	PN 10	180	8 x M16	100	670	670	750	51	205
	PN 16	180	8 x M16						
	ANSI B16.5 150lb	190.5	8 x 5/8"						
125	PN 10	210	8 x M16	125	710	710	840	57	205
	PN 16	210	8 x M16						
	ANSI B16.5 150lb	216	8 x 3/4"						
150	PN 10	240	8 x M20	150	840	840	930	57	205
	PN 16	240	8 x M20						
	ANSI B16.5 150lb	241.5	8 x 3/4"						
200	PN 10	295	8 x M20	200	1005	1005	1170	70	205
	PN 16	295	12 x M20						
	ANSI B16.5 150lb	298.5	8 x 3/4"						
250	PN 10	350	12 x M20	250	1200	1200	1390	70	315
	PN 16	355	12 x M24						
	ANSI B16.5 150lb	362	12 x 7/8"						
300	PN 10	400	12 x M20	300	1400	1400	1620	76	315
	PN 16	410	12 x M24						
	ANSI B16.5 150lb	432	12 x 7/8"						
350	PN 10	460	16 x M20	350	1600	1600	1850	76	315
	PN 16	470	12 x M24						
	ANSI B16.5 150lb	476	12 X1"						
400	PN 10	515	16 x M24	400	1170	1170	2080	89	315
	PN 16	525	16 x M27						
	ANSI B16.5 150lb	540	16 x 1"						
450	PN 10	565	20 x M24	450	2010	2010	2240	89	315
	PN 16	585	20 x M27						
	ANSI B16.5 150lb	578	16 x 1-1/8"						
500	PN 10	620	20 x M24	500	2130	2130	2370	114	400
	PN 16	650	20 x M30						
	ANSI B16.5 150lb	578	20 x 1-1/8"						
600	PN 10	725	20 x M27	600	2570	2570	2680	114	400
	PN 16	770	20 x M27						
	ANSI B16.5 150lb	749.5	20 x 1-1/4"						

Dimensions given above are indicative, contact Jash for certified drawings. Dimensions of higher sizes upon request

## "ZFI" SERIES KNIFE GATE VALVES

ZFI series knife gate valves are manufactured under collaboration with Schütte group, Germany. The ZFI series valves are bonnetless knife gate valves having glands with packings to seal the rear opening in the housing. These valves are suitable for unidirectional application and are leak tight in case of resilient seat valves. Metal seated valves offer leakage within permissible limits as per MSS SP-81 standard.

These can be installed in vertical / horizontal as well as in inclined position. The ZFI series knife gate valves can be used for liquid, solid-liquid mixes / slurries, dry bulk solids. These are provided with 90% bore opening which minimizes / restricts flow in pipeline.

### Salient features of ZFI series knife gate valves:

- A lug type design of sleek construction having low face to face dimension for mounting in compact installation.
- Varied sealing configurations such as integral metal seated, resilient seat retained with replaceable metallic seat retainer ring and resilient seat retained by metallic strip / band.
- Sealing achieved by means of integrally cast / welded jams pushing the gate on to the seat for a full face contact between gate and seat.
- Gate having beveled knife-edge at its front to cut through solid particles settled at bottom of body and achieve full closure.
- Self lubricated gland packings for closure of rear opening in the housing.
- Packing glands provided with pushing arrangement to tighten on the gate and stop the leakage taking place from the rear opening in the housing due to frequent gate operation.
- Provided with purging holes to purge the material retained in valve housing.
- Rising spindle or non rising spindle as per requirement.
- Manual / Pneumatic / Electric / Hydraulic operation as per requirement.

The ZFI series valves are offered in various variants as under:

- **ZFI-M:** Integral metal seated.
- **ZFI-S:** Resilient seat retained by metallic seat retainer strip / band.
- **ZFI-SRR:** Resilient seat retained with replaceable metallic seat retainer ring.

### Standard technical specifications:

Manufacturing standard	- As per MSS SP-81 standard
Lug / flange provision	- Semi lugged up to DN 600 & full flanged above DN 600
Flange drilling	- Suitable for DIN PN 10 / IS 1538 / BS 4504 as well as ANSI B16.5 150lb
Flange to flange distance	- As per MSS SP-81
Sealing configuration	- Integral metal seated in " <b>ZFI-M</b> " variant Resilient seat retained with replaceable metallic seat retainer ring in <b>ZFI-SRR</b> variant Resilient seat retained by metallic seat retainer strip / band in " <b>ZFI-S</b> " variant Non integral metal seated option available on request.
Pressure rating	- PN 10 (150 psig) rated upto DN 300 & PN 6 (90 psig) rated from DN 350 to DN 600
Nominal size	- DN 50 – DN 4000 (" <b>ZFI-S</b> " is available up to DN 600 only)



Full flanged design valve

## "ZFI" KNIFE GATE VALVES



Semi lugged design valve

### Material of construction options for major components:

Housing	- Cast Iron FG 260 / Ductile iron as per ASTM A 536 Grade 65-45-12 / Cast carbon steel ASTM A 216 Grade WCB / Cast stainless steel ASTM A 351 Grade CF: 8 / CF: 8M / CF: 3M
Gate	- Stainless steel ASTM A 240 Grade 304 / 316 / 316L
Resilient seat	- NBR / EPDM / VITON
Stem	- Carbon steel AISI: 1117 / Stainless steel ASTM A 276 Grade 410 / 304 & 316
Packing	- Synthetic yarn with PTFE impregnation, Graphited yarn

Materials other than those stated above can also be offered on request.

### Painting:

External	- Fusion bonded epoxy or epoxy painted depending upon size & client requirement only on all non-stainless steel parts Total dry film thickness maintained 250 microns minimum
----------	--

### Testing:

Body test	- As per MSS SP-81 norms up to DN 900 / As agreed mutually for higher sizes
Leakage criterion	- Zero leakage as per MSS SP-81 for resilient seated valves - 40 cc / min / inch as per MSS SP-81 for metal seated valves

All valves are tested prior to shipping in line with details mentioned above.

Part No.	Description
1	Housing
2	Seal retainer ring
3	Metallic band
4	Resilient seat
5	Gate
6	Stuffing seal
7	Spindle
8	Supporting bracket
9	Hand wheel

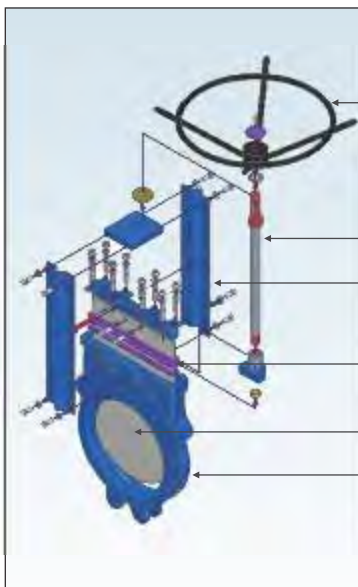

Exploded view of ZFI-M valves

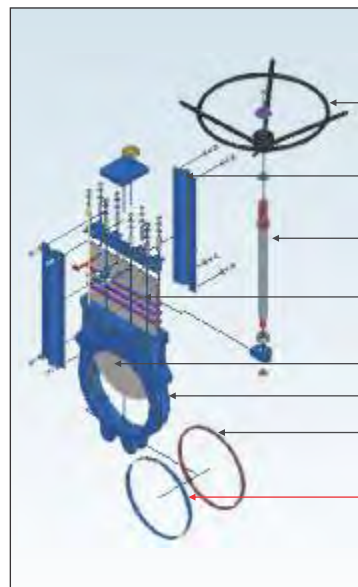

Exploded view of ZFI-S valves

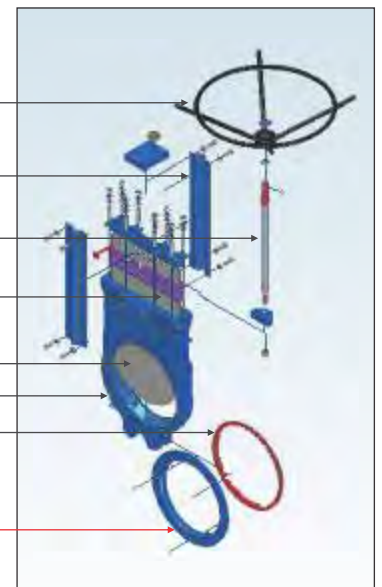

Exploded view of ZFI-SRR valves



## "ZFI" KNIFE GATE VALVE - DIMENSIONAL DETAILS UPTO DN 600

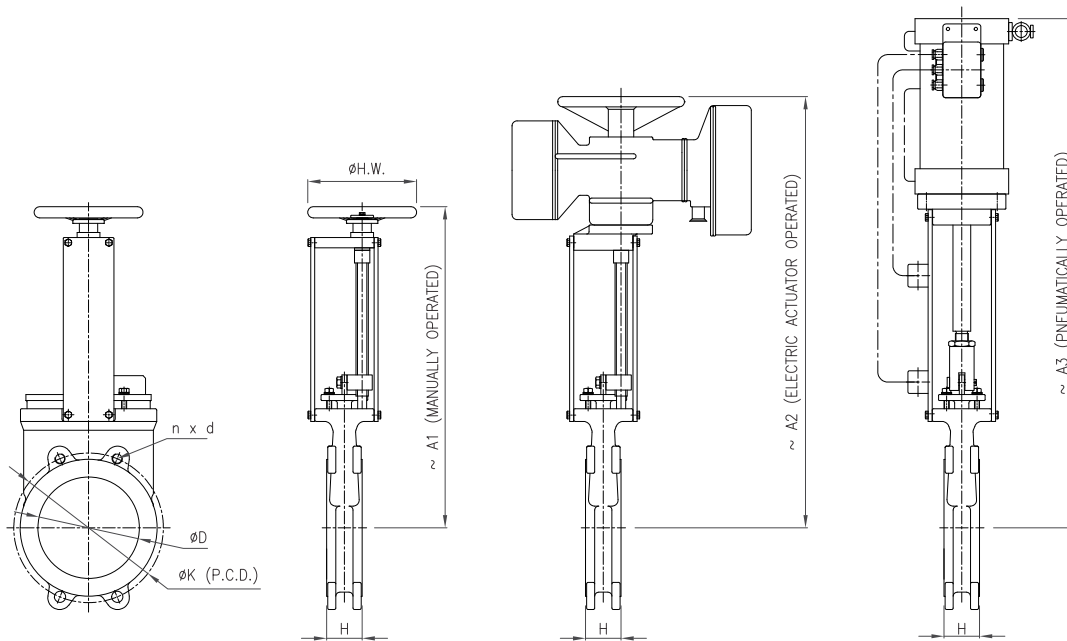

DN	Flange drilling	$\phi K$	$n \times d$	$\phi D$	$\sim A1$	$\sim A2$	$\sim A3$	$\sim H$	$\sim \phi H.W.$
50	DIN PN 10	125	4 x M16	50	370	570	580	51	205
	ANSI B16.5 150lb	121	8 x 5/8"						
80	DIN PN 10	160	8 x M16	80	400	620	655	51	205
	ANSI B16.5 150lb	152.5	4 x 5/8"						
100	DIN PN 10	180	8 x M16	100	450	660	705	51	205
	ANSI B16.5 150lb	190.5	8 x 5/8"						
125	DIN PN 10	210	8 x M16	125	510	725	780	57	205
	ANSI B16.5 150lb	216	8 x 3/4"						
150	DIN PN 10	240	8 x M20	150	560	765	840	57	205
	ANSI B16.5 150lb	241.5	8 x 3/4"						
200	DIN PN 10	295	8 x M20	200	640	850	1050	70	205
	ANSI B16.5 150lb	298.5	8 x 3/4"						
250	DIN PN 10	350	12 x M20	250	770	980	1240	70	315
	ANSI B16.5 150lb	362	12 x 7/8"						
300	DIN PN 10	400	12 x M20	300	880	1075	1500	76	315
	ANSI B16.5 150lb	432	12 x 7/8"						
350	DIN PN 10	460	16 x M20	350	1120	1200	1650	76	315
	ANSI B16.5 150lb	476	12 x 1"						
400	DIN PN 10	515	16 x M24	400	1200	1270	1760	89	400
	ANSI B16.5 150lb	540	16 x 1"						
450	DIN PN 10	565	20 x M24	450	1280	1370	1880	89	400
	ANSI B16.5 150lb	578	16 x 1-1/8"						
500	DIN PN 10	620	20 x M24	500	1470	1560	2200	114	635
	ANSI B16.5 150lb	635	20 x 1-1/8"						
600	DIN PN 10	725	20 x M27	600	1650	1780	2250	114	635
	ANSI B16.5 150lb	749.5	20 x 1-1/4"						

Dimensions given above are indicative, contact Jash for certified drawings

## "ZFI" KNIFE GATE VALVE - DIMENSIONAL DETAILS ABOVE DN 600

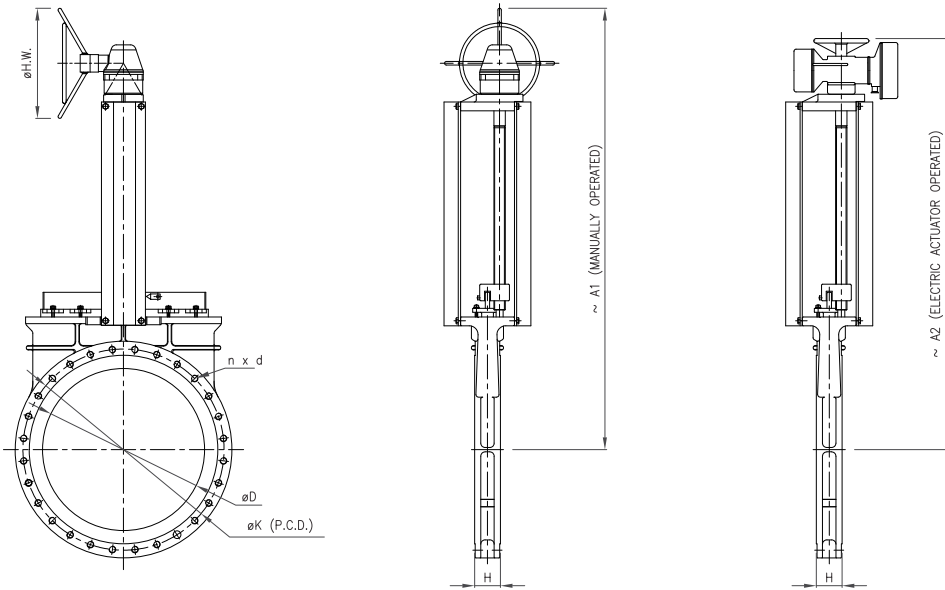

DN	Flange drilling	$\phi K$	$n \times d$	$\phi D$	$\sim A1$	$\sim A2$	$\sim H$
700	PN 10	840	24 x M27	700	1725	1595	120
	ANSI 150 B 16.47	864	28 x 1-1/4"				
800	PN 10	950	24 x M30	800	1790	1660	120
	ANSI 150 B 16.47	978	28 x 1-1/2"				
900	PN 10	1050	28 x M30	900	2035	1905	120
	ANSI 150 B 16.47	1086	32 x 1-1/2"				
1000	PN 10	1160	28 x M33	1000	2310	2175	130
	ANSI 150 B 16.47	1200	36 x 1-1/2"				
1200	PN 10	1380	32 x M36	1200	2575	2445	135
	ANSI 150 B 16.47	1423	44 x 1-1/2"				
1400	PN 10	1590	36 x M39	1400	3000	2870	170
	ANSI 150 B 16.47	1651	48 x 1-3/4"				
1500	PN 10	1700	36 x M39	1500	3135	2900	170
	ANSI 150 B 16.47	1759	52 x 1-3/4"				
1600	PN 10	1820	40 x M45	1600	3330	3005	230
	AWWA C207	1930	52 x 1-3/4"				
1800	PN 10	2020	44 x M45	1800	3800	3670	230
	AWWA C207	2096	60 x 1-3/4"				
2000	PN 10	2230	48 x M45	2000	4060	3930	240
	AWWA C207	2261	64 x 1-7/8"				

Dimensions given above are indicative, contact Jash for certified drawings. Dimensions of higher sizes upon request

## OPTIONAL FEATURES

Popular optional features requested generally are explained below. Other special features specific to clients application & requirement can be offered on request.

### 1. Bi-directional seating:

Depending upon application some valves are subjected to full applicable pressure from both directions. Such valves are provided with sealing arrangement on either side of gate to achieve bi-directional shut-off.

### 2. Deflection cone:

Deflection cone is put in the material flow area to prevent erosion of valve housing in abrasive application. When a deflection cone is not used, the valve housing will get eroded and it is very expensive to replace valve housing in comparison to replacement of deflection cone. Deflection cones are available in Ni-hard/Alloy cast iron construction.

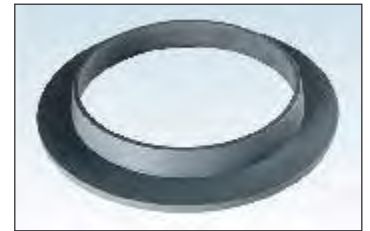

### 3. Flush / purging ports:

Flush / Purging ports are provided for cleaning of material trapped in the body cavity. These ports are typically placed on the valve chest / bottom of the valve or as required.

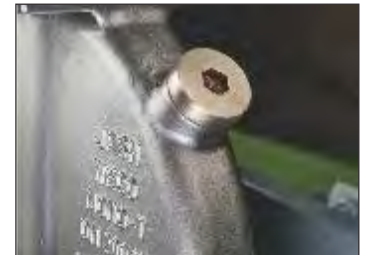

### 4. V-port design:

V-port design valves are used for throttling applications. "V" notch is welded in the material flow area.



### 5. Hardening on seat & gate:

Depending upon application and service conditions, valve components can go through additional processes to increase their life. Process like hard stellite facing on flow bore area and gate edge is done to prevent surface erosion from abrasive media. Similarly nitriding, galvanizing, hard chrome plating, nylon coating etc can be provided on gate plate to prolong its life.



#### 6. Bolt on bonnet:

Non bonneted valves can be provided with provision of bolt on casted or fabricated bonnet to ensure tight sealing to atmosphere.

Bonneted valves can be provided with various options such as pressurized or un-pressurized bonnet area, drain ports for flushing bonnet area and provision for packing to be replaced with valve under pressurized condition.



#### 7. Protection cover for pneumatic/hydraulic actuated valves:

Non bonneted valves can be provided with gate safety guards to prevent any accidental injury due to the fast moving gate in pneumatically and hydraulically actuated valve.



#### 8. Pipe hood for stem:

Pipe hood arrangement can be provided to prevent accidental injury due to rising spindle / stem and to cover the spindle threads for protection against damage, dirt, dust, water etc. Pipe hood can be made of transparent fracture resistant polycarbonate material / metallic pipe / plastic pipe.



#### 9. Extended spindle arrangement:

Extended spindle allows the operator to open or close the valve from a distance. Extended spindle arrangement includes couplings, stem guide bracket, pillars and necessary fasteners.

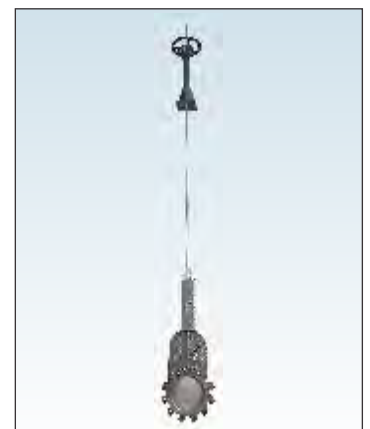

## MODES OF OPERATION

Popular modes of operation requested generally are illustrated by photographs below. Other special modes of operation specific to clients application and requirement can be offered on request.



Hand wheel operated



Lever operated



Gear box operated



Chain wheel operated



Electric actuator operated



Pneumatically operated



Pneumatically operated with manual override provision



Pneumatically operated with electro pneumatic positioner



Hydraulically operated

Manual valves with gear boxes can also be offered with portable actuator which is either battery or engine driven

**SPECIAL VALVES**



*DN 1600, Super duplex steel knife gate valve for Vatech Wabag, Nemmeli desalination project, Chennai, India*



*DN 750, Low operating torque, bonneted, Stainless steel knife gate valve for Raphael Valves, Israel*



*DN 1500, Bi-directional Stainless steel knife gate valve for Stealth Valves & Controls, Canada*



*Size 500 x 325 mm, Resilient seated, Super duplex steel slide gate valve for Degremont, Mirfa-IWPP De-salination project, Abu-Dhabi, UAE*



*DN 200, Stainless steel knife gate valve for Thermax, Captive power plant of RIL, Dahej/Hazira, India*





*Jash corporate office, Indore, India*

**Jash Engineering Ltd.**

31, Sector 'C', Industrial Area,  
Sanwer Road, Indore - 452015 (M.P.), INDIA  
Ph.: 0091-731-2720143, 2721143, 4232900,  
email : [info@jashindia.com](mailto:info@jashindia.com), Website : [www.jashindia.com](http://www.jashindia.com)

**Jash USA Inc.**

9505 Aerospace Drive, Suite100, Saint Louis, MO 63134, USA  
Ph.: (314) 449-8310, Mobile: (636) 284-8349,  
email: [info@jashusa.com](mailto:info@jashusa.com), Website: [www.jashusa.com](http://www.jashusa.com)

**Mahr Maschinenbau Ges.m.b.H**

Kupferschmiedgass 8, A-2201 Hagenbrunn, AUSTRIA  
Ph.: + 432246 3521  
email : [office@mahr.at](mailto:office@mahr.at), Website: [www.mahrmaschinenbau.com](http://www.mahrmaschinenbau.com)

**Engineering & Manufacturing Jash Ltd.**

27/F, Tesbury Centre,  
28 Queen's Road East, HONG KONG  
Ph.: +(2731) 5727770  
email : [info@jashindia.com](mailto:info@jashindia.com)  
Website: [www.engineering-and-manufacturing.com](http://www.engineering-and-manufacturing.com)



Pictures shown are general, unless specific job names are listed.  
Manufacturer reserves the right to depart from the catalogue specifications and illustrations.